

## Avantco CPT-48 47" Countertop Refrigerated Prep Rail

Item #360CPT48



### Technical Data

Width	47 1/4 Inches
Depth	15 9/16 Inches
Height	11 1/2 Inches
Hertz	60 Hertz
Phase	1 Phase
Voltage	115 Volts
1/3 Size Pan Capacity	4 Pans
1/6 Size Pan Capacity	8 Pans
BTU (LBP)	402
Color	Silver
Compressor Location	Side Mounted
Horsepower	1/6 HP
Lid Type	Hinged
Number of Compartments	4 - 8 Compartments
Plug Type	NEMA 5-15P
Power Type	Electric
Refrigerant Type	R-600a
Temperature Range	33 - 41 Degrees F
Total BTU	402 BTU

### Features

- Holds up to (4) 1/3 size 6" deep or (8) 1/6 size 6" deep food pans (sold separately)
- Lift-up lid for easy access and food safety
- Made of durable type 201 stainless steel for corrosion-resistance with built-in non-scratch feet
- Temperature range of 33 to 41 degrees Fahrenheit; electronic thermostat with digital display
- Uses eco-friendly R600a refrigerant; 115V

### Certifications



5-15P



ETL Sanitation



ETL US & Canada

## Plan View

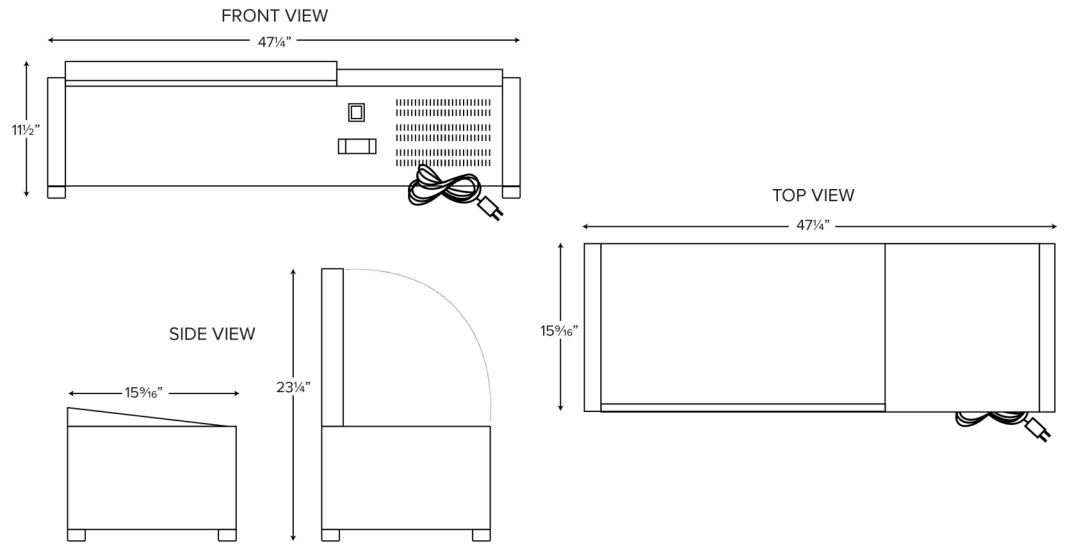

## Notes & Details

Keep all your essential ingredients and prep items nearby with this Avantco CPT-48 47" refrigerated countertop prep rail. Perfect for storing items such as sliced tomatoes, pickles, relish, onions, and lettuce, this unit increases the ease of prep work. It ensures the condiments, sandwich toppings, or salad ingredients are kept at the appropriate temperature but still close at hand.

If you need a prep station for your restaurant or cafe, this prep rail is a great choice! It offers the cold storage area you need for your condiments but can be placed on your own countertop. This is especially important if you don't have the budget or the space for a full prep refrigerator. This model can hold a total of (4) 1/3 size or (8) 1/6 size food pans (sold separately) and comes with pan support bars. Additionally, a stainless steel hinged cover can be closed to prevent loss of temperature and protect against airborne contaminants.

Exterior and interior type 201 stainless steel construction ensures long-lasting durability and corrosion-resistance. Non-scratch plastic feet provide stability and keep it from sliding or leaving marks on your countertop. A self-contained refrigeration system uses eco-friendly R600a refrigerant, providing reliable and even cooling throughout the unit. R600a refrigerant has an ozone depletion potential (ODP) of 0 and a global warming potential (GWP) of 3. As a result, the unit is an environmentally-responsible choice for your business.

This unit has an integrated electronic thermostat that allows you to set the temperature between 33 and 41 degrees Fahrenheit. Its external digital LED panel displays the set temperature so you can make sure that it is always set at the correct holding temperature for your food. This unit requires a 115V electrical connection for operation and includes a 5' cord.

This unit should only be used during operational hours to maintain the cold temperature of pre-chilled food. It should not be used for continuous or long term storage, but rather maintained with a daily emptying and cleaning.

**⚠ WARNING:** This product can expose you to chemicals including lead, which are known to the State of California to cause cancer, birth defects, or other reproductive harm. For more information, go to [www.p65warnings.ca.gov](http://www.p65warnings.ca.gov).