

Item #: 178SSPPT3I Project: _____

Qty: _____ Date: _____ Approval: _____

Avantco SSPPT-3I 93" 2 Door Refrigerated Pizza Prep Table with 2 Drawers

Item #178SSPPT3I



Technical Data

Width	93 13/16 Inches
Depth	31 1/2 Inches
Height	43 Inches
Power Cord Length	98 1/2 Inches
Cutting Board Width	93 13/16 Inches
Interior Width	73 1/4 Inches
Nominal Width	93 Inches
Cutting Board Depth	19 7/16 Inches
Depth (with cutting board)	37 1/8 Inches
Interior Depth	26 3/16 Inches

Features

- Top rail accommodates up to (12) 1/3 size food pans up to 6" deep
- Cutting board built-in for convenient prep space
- Maintains temperatures between 33 and 40 degrees Fahrenheit
- Stainless steel exterior and interior; two built-in drawers for added storage
- 120V; R290 refrigerant, 1/2 hp; 3.14 Amps

Certifications



ETL Sanitation



ETL, US & Canada



5-15P



Technical Data

Height with Lid Open	56 3/4 Inches
Interior Height	22 13/16 Inches
Work Surface Height	35 1/4 Inches
Amps	3.14 Amps
Phase	1 Phase
Voltage	120 Volts
1/3 Size Pan Capacity	12 Pans
Access Type	Doors and Drawers
BTU (LBP)	1285 BTU
Compressor Location	Side Mounted
Compressor Style	Side / Rear Breathing
Construction	Stainless Steel
Door Style	Swing
Door Type	Solid
Horsepower	1/2 HP
Installation Type	Freestanding
Number of Doors	2 Doors
Number of Drawers	2 Drawers
Number of Shelves	2 Shelves
Plug Type	NEMA 5-15P
Refrigerant Type	R-290
Refrigeration Type	Air Cooled
Temperature Range	33 - 40 Degrees F
Top Capacity	353 lb.

Plan View

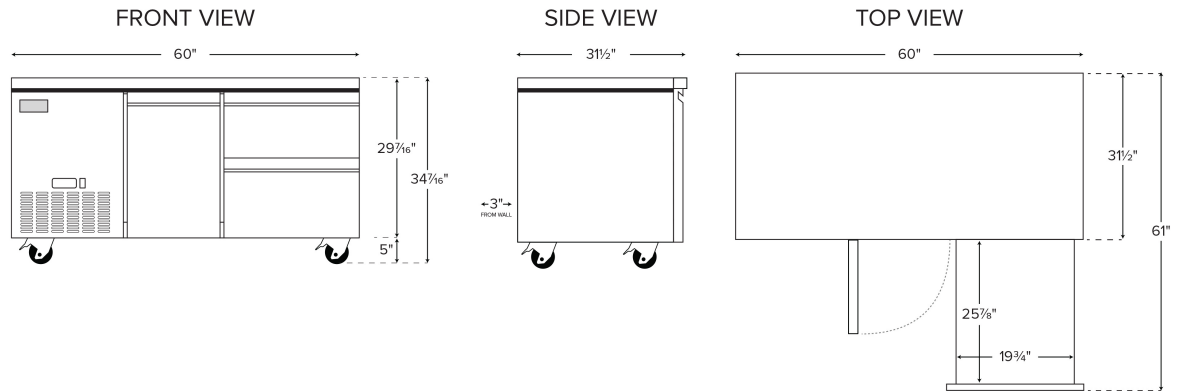

BIG DRAWER SIDE SIDE VIEWS

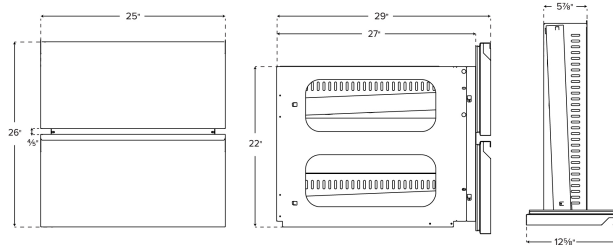

BIG DRAWER TOP VIEWS

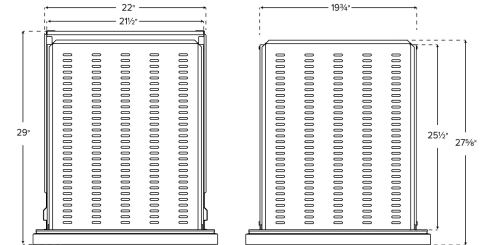



Notes & Details

Optimize your back-of-house operations with this Avantco SSPPT-31 93" 2 door refrigerated pizza prep table with 2 drawers, and better keep up with customer demands. Whether used in a university, pizza parlor, or resort, the unit will help streamline the pizza prep process with its convenient features and capacity. Its top rail, for instance, accommodates up to (12) 1/3 size food pans up to 6" deep (sold separately). These are great for holding common pizza toppings, from pepperoni and cheese to green pepper or ham. Plus, a lift-up lid encloses the pan rail to maintain proper, food safe temperatures. A full-length cutting board is mounted to the table surface, providing a place for slicing ingredients and assembling pies.

Beneath the workspace is additional storage. Because it's refrigerated, the space is great for storing back-up ingredients, such as sauce and dough, as well as less-common toppings. The right side and middle are open cavities behind two doors, and they contain two epoxy-coated shelves that can each accommodate up to 90 lb. of weight, helping to organize your assorted supplies. On the left side, the unit includes two built-in drawers to provide even more storage while allowing you to sort specific product. Drawers provide excellent organization for your food pans and can help maximize your kitchen's workflow. Drawers also allow you to quickly pull ingredients for faster operation and ease of use. This unit comes equipped with 6 divider bars.

High-quality performance is made possible by the unit's 1/2 hp refrigeration system, which maintains temperatures between 33 and 40 degrees Fahrenheit. It circulates R290 refrigerant, which has an ozone depletion potential (ODP) of 0 and a global warming potential (GWP) of 3.

The construction of this unit is designed with commercial use in mind. It features a 430 type stainless steel exterior and 304 type stainless steel interior, which are fortified with foamed-in-place polyurethane insulation. The insulation also helps to promote proper temperature retention. For operation, the prep table requires a 120V electrical connection.

⚠ WARNING: This product can expose you to chemicals including lead, which are known to the State of California to cause cancer, birth defects, or other reproductive harm. For more information, go to www.p65warnings.ca.gov.