

Item #: 178CPW47HC Project: \_\_\_\_\_

Qty: \_\_\_\_\_ Date: \_\_\_\_\_ Approval: \_\_\_\_\_



## Avantco CPW-47-HC 47 1/8" 8 Tub White Ice Cream Dipping Cabinet

Item #178CPW47HC



### Technical Data

Width	47 1/8 Inches
Depth	28 Inches
Height	51 1/4 Inches
Power Cord Length	98 7/16 Inches
Interior Width	41 1/4 Inches
Interior Depth	22 Inches
Interior Height	28 15/16 Inches
Amps	5.2 Amps
Hertz	60 Hertz
Phase	1 Phase
Voltage	115 Volts
BTU (LBP)	2456 BTU
Cabinet Type	Merchandising
Capacity	15.2 cu. ft.
Compressor Location	Bottom Mounted
Container Display Capacity	8 Cans
Exterior Material	White-Coated Steel
Features	Automatic Electric Defrost
Front Style	Flat
Horsepower	1 HP
Individual Shelf Capacity	33 lb.
Insulation Material	Cyclopentane
Interior Material	Precoated Aluminum Plate
Maximum Ambient Temperature	90 Degrees F
Number of Shelves	4 Shelves
Plug Type	NEMA 5-15P
Refrigerant Type	R-290
Temperature Control	Digital
Temperature Range	-15 - -11 Degrees F
Total Container Capacity	13 Cans
Type	Dipping Cabinets

### Features

- Displays up to 8 ice cream tubs; stores up to 4 tubs beneath (capacity measured in 3 gallon tubs)
- White design helps showcase colorful flavors and samples
- Features stainless steel shelf on top of canopy for spoons, samples, and other supplies
- Uses R290 refrigerant
- 115V, 1 hp; 5.2 Amps
- Includes tub inserts and covers

### Certifications



ETL US



5-15P



ETL Sanitation

Avantco Refrigeration

## Plan View

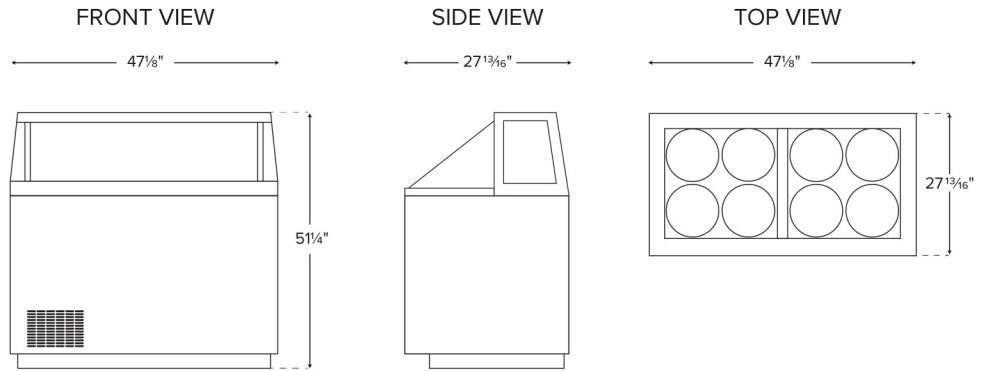

## Notes & Details

Display, merchandise, and serve a delicious variety of ice cream flavors with this Avantco CPW-47-HC white deluxe ice cream dipping cabinet! Holding up to 8 ice cream tubs at a time, the unit is perfect for ice cream shops, candy stores, dessert bars, and cafeterias. The frozen storage space beneath the display even provides a convenient place for holding up to 4 tubs of back-up flavors, making it a convenient unit for businesses with limited space.

Outfitted with a glass canopy, the dipping cabinet is perfect for front-of-house applications. A deep shelf is built on top of the canopy too, which is ideal for placing sampling spoons, cups, promotional materials, and prepared orders. Not only does the canopy prevent customers from contaminating the product, but it ensures crystal-clear visibility for merchandising purposes. By showcasing bright, fruity or dark and decadent, chocolatey flavors behind the glass and illuminating it with LED lighting, you tempt customers into trying a bite -- or a few! A sliding cover also protects the ice cream, while helping to retain cold air around the product for a safe holding environment. Because it slides open and closed, it's fast and easy to use, too, which is perfect for those busy rush hours or constant streams of customers in the summer months!

This dipping cabinet ensures optimal performance by operating with a 1 hp refrigeration system that circulates R290 hydrocarbon refrigerant to maintain temperatures from -15 to -8 degrees Fahrenheit. R290 refrigerant has an ozone depletion potential (ODP) of 0 and a global warming potential (GWP) of 3.

With a smooth, white design, the unit is built for long-lasting use in a variety of business settings. A 115V electrical connection is required for operation.

**⚠ WARNING:** This product can expose you to chemicals including lead, which are known to the State of California to cause cancer, birth defects, or other reproductive harm. For more information, go to [www.p65warnings.ca.gov](http://www.p65warnings.ca.gov).