

CPT Series Countertop Refrigerated Prep Rail

MODELS #360CPT40HC, #360CPT40HCSG (with Sneeze Guard)

REFRIGERATION
AVANTCO

www.AvantcoRefrigeration.com

CPT SERIES - COUNTERTOP PREP RAILS

Perfect for turning any workspace into a prep station. Increases the ease of prep work by fitting where a full size prep table could not, and can also be used as a self-serve ingredient station for customers.

CABINET CONSTRUCTION

Durable type 201 stainless steel construction with hinged lid(s). Optional glass sneeze guard available.

Compact, countertop design with shallow depth requires minimal space and leaves counter room at the front of the unit.

REFRIGERATION SYSTEM

1/4 hp compressor uses R600a refrigerant. Operation requires a 115V electrical connection.

Cold wall design keeps food cold even with repeated lid opening.

STORAGE

Includes pan support bars to hold food pans.

MODEL FEATURES

Intuitive, easy to read pre-programmed electronic controls.

Operates in an ambient temperature up to 90°F.

Foamed-in-place polyurethane insulation.

Manual defrost system.

SPECIAL FEATURES

- Holds up to (3) 1/3 size food pans (sold separately)
- Compact, countertop design gives customers easy access to condiments
- Eco-friendly R600a hydrocarbon refrigerant
- Hinged lid closes off food pans for safety from contaminants without needing individual lids
- Optional glass sneeze guard showcases condiments while preventing contamination
- Intuitive digital temperature controls with back-lit light switch
- Maintains a temperature range from 33 to 40°F
- Durable type 201 stainless steel holds up to wear-and-tear
- Non-scratch feet will not leave marks on your countertop
- 115V, 1/4 hp



WARRANTY

RESIDENTIAL: Avantco assumes no liability for parts or labor coverage for component failure, factory defect or any other damages for units installed in non-commercial foodservice or residential applications.



Replacement



CPT Series Countertop Refrigerated Prep Rail



www.AvantcoRefrigeration.com

MODELS #360CPT40HC, #360CPT40HCSG (with Sneeze Guard)

TECHNICAL DATA

Dimensions

Exterior Dimensions	39 ³ / ₈ "W x 15 ¹ / ₂ "D x 9 ¹ / ₄ "H
Exterior Dimensions with Sneeze Guard	39 ³ / ₈ "W x 15 ¹ / ₂ "D x 17 ¹ / ₈ "H
Interior Dimensions	25 ¹ / ₂ "W x 12 ¹ / ₄ "D x 6 ¹ / ₂ "H
Height with Lid Open	23 ¹ / ₄ "
Capacity	(3) 1/3 size pans
Net Weight	55 lb.
Gross Weight	66 lb.
Packaging Dimensions	41"W x 17 ³ / ₄ "D x 17 ¹ / ₂ "H
Packaging Dimensions with Sneeze Guard	41"W x 17 ³ / ₄ "D x 17 ¹ / ₂ "H 40 ¹ / ₂ "W x 17 ¹ / ₂ "D x 2 ¹ / ₄ "H

Cooling

Temperature Range	33°-40°F
Refrigerant	R600a
Max Ambient Temperature	90°F
Defrosting	Manual
Temperature Controller	Digital
Horsepower	1/4
BTU (BTU/HR)	682

Electrical

Voltage	115
Amps	1.6
Hz	60
Phase	1
Plug	NEMA 5-15p
Cord Length	60"

Construction

Exterior Material	SS201
Interior Material	SS201
Door Type	Hinged Metal Lid
Insulation	Foamed-In-Place Polyurethane

PLAN VIEW

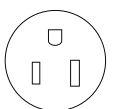
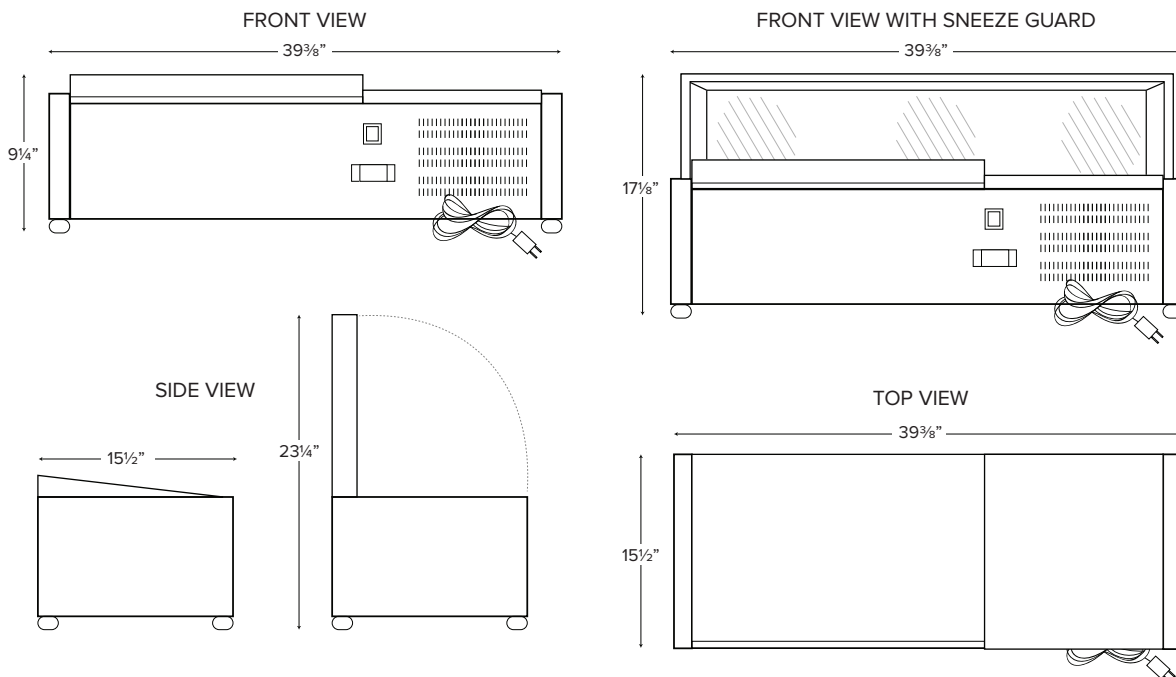

NEMA 5-15P