

GDC Series Glass Door Merchandiser

REFRIGERATION
AVANTCO

MODEL #178GDC49HCB, #178GDC49FHCB

www.AvantcoRefrigeration.com

GDC SERIES - GLASS DOOR REFRIGERATOR

Used for the merchandising and storage of hermetically sealed products for sale.

CABINET CONSTRUCTION

Heavy duty construction includes black or white-coated aluminum interior walls and stainless steel floor. Exterior features black or white peel and chip-resistant, powder-coated cold rolled steel that is durable and permanent.

Foamed-in-place CFC- and HCFC-free polyurethane insulation enhances the structural strength of the cabinet and helps increase energy efficiency.

One-piece grill is easily removed for cleaning and servicing.

2 dual-pane tempered glass swing doors self-close to save energy.

REFRIGERATION SYSTEM

Environmentally-safe R290 refrigerant. Bottom mount condensing unit positioned for easy maintenance. "No stoop" lower shelf maximizes visibility by raising merchandised product to a higher level.

SHELVING

8 epoxy-coated steel shelves accommodate up to 90 lb. each.

MODEL FEATURES

Copper evaporator coil eliminates the potential of corrosion.

Convenient clean-out drain built into cabinet floor.

Digital controller features auto-defrost function.

LED lighted interior saves energy by producing less heat and maximizes product visibility in display area.

SPECIAL FEATURES

- Eco-friendly R290 hydrocarbon refrigerant
- 2 self-closing, glass swing doors
- 8 epoxy-coated steel shelves each holds up to 90 lb. of weight
- Bright, LED lighting
- Maintains temperatures between 33° and 40°F
- Easy-to-use, digital temperature controls
- Foamed-in-place polyurethane insulation
- Black or white coated steel exterior and painted aluminum interior
- Stainless steel floor
- Auto defrost for easy maintenance
- 115V, 1 hp



WARRANTY

RESIDENTIAL: Avantco assumes no liability for parts or labor coverage for component failure, factory defect or any other damages for units installed in non-commercial foodservice or residential applications.



Parts & Labor



Compressor

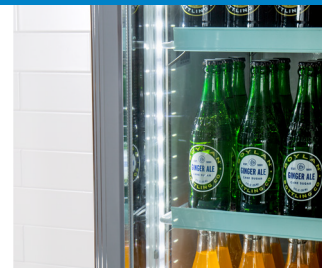

GDC Series Glass Door Merchandiser

MODELS #178GDC49HCB



www.AvantcoRefrigeration.com

TECHNICAL DATA

Dimensions

Exterior Dimensions	53 $\frac{1}{8}$ "W x 31 $\frac{7}{8}$ "D x 84 $\frac{3}{8}$ "H
Interior Dimensions	50"W x 28 $\frac{3}{8}$ "D x 61 $\frac{7}{8}$ "H
Net Volume	42.5 cu. ft.
Net Weight	437 lb.
Gross Weight	480 lb.
Packaging Dimensions	54 $\frac{1}{4}$ "W x 33"D x 84 $\frac{1}{2}$ "H

Construction

Exterior Material	Black or white Coated Steel
Interior Material	Painted Aluminum
Door Type	Glass Swing
Insulation Material	Foamed-In-Place Polyurethane
Shelf Size	(8) 24 $\frac{3}{8}$ " x 23 $\frac{5}{8}$ "
Shelf Material	Plastic-Coated Steel
Shelf Load Capacity	90 lb.

Cooling

Temperature Range	33°F-40°F
Refrigerant	R290
Max. Ambient Temperature	90
Defrosting	Automatic
Temperature Controller	Digital
Horsepower	1/4

Electrical

Voltage	115
Amps	4.5
Hz	60
Phase	1
Plug Type	NEMA 5-15P
Electrical Cord Length	96"

PLAN VIEW

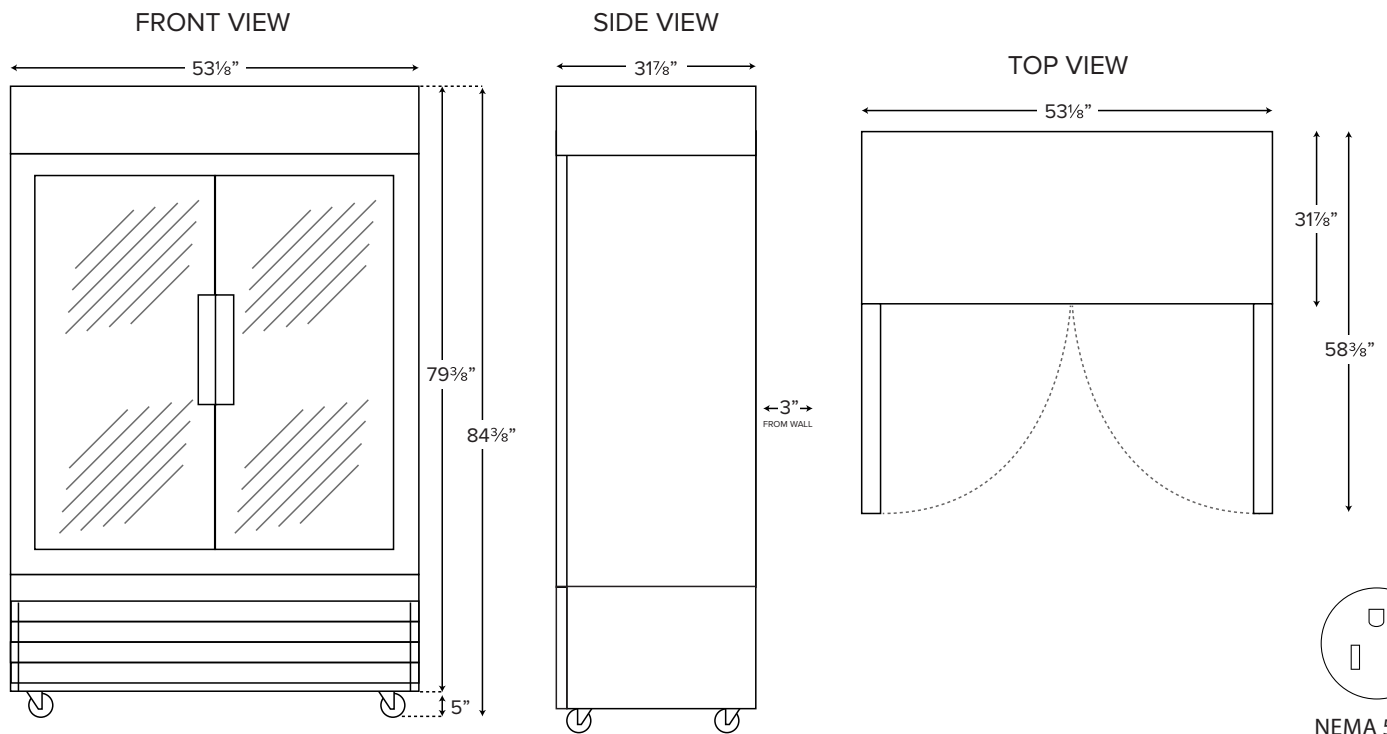

GDC Series Glass Door Merchandiser

REFRIGERATION
AVANTCO

www.AvantcoRefrigeration.com

MODEL #178GDC49HCW, #178GDC49FHCB

GDC SERIES - GLASS DOOR REFRIGERATOR

Used for the merchandising and storage of hermetically sealed products for sale.

CABINET CONSTRUCTION

Heavy duty construction includes black or white-coated aluminum interior walls and stainless steel floor. Exterior features black or white peel and chip-resistant, powder-coated cold rolled steel that is durable and permanent.

Foamed-in-place CFC- and HCFC-free polyurethane insulation enhances the structural strength of the cabinet and helps increase energy efficiency.

One-piece grill is easily removed for cleaning and servicing.

2 dual-pane tempered glass swing doors self-close to save energy.

REFRIGERATION SYSTEM

Environmentally-safe R290 refrigerant. Bottom mount condensing unit positioned for easy maintenance. "No stoop" lower shelf maximizes visibility by raising merchandised product to a higher level.

SHELVING

8 epoxy-coated steel shelves accommodate up to 90 lb. each.

MODEL FEATURES

Copper evaporator coil eliminates the potential of corrosion.

Convenient clean-out drain built into cabinet floor.

Digital controller features auto-defrost function.

LED lighted interior saves energy by producing less heat and maximizes product visibility in display area.

SPECIAL FEATURES

- Eco-friendly R290 hydrocarbon refrigerant
- 2 self-closing, glass swing doors
- 8 epoxy-coated steel shelves each holds up to 90 lb. of weight
- Bright, LED lighting
- Maintains temperatures between 33° and 40°F
- Easy-to-use, digital temperature controls
- Foamed-in-place polyurethane insulation
- Black or white coated steel exterior and painted aluminum interior
- Stainless steel floor
- Auto defrost for easy maintenance
- 115V, 1 hp



WARRANTY

RESIDENTIAL: Avantco assumes no liability for parts or labor coverage for component failure, factory defect or any other damages for units installed in non-commercial foodservice or residential applications.



Parts & Labor



Compressor



GDC Series Glass Door Merchandiser

MODELS #178GDC49HCW, #178GDC49FHCB



www.AvantcoRefrigeration.com

TECHNICAL DATA

Dimensions

Exterior Dimensions	53 $\frac{1}{8}$ "W x 31 $\frac{7}{8}$ "D x 84 $\frac{3}{8}$ "H
Interior Dimensions	50"W x 28 $\frac{3}{8}$ "D x 61 $\frac{7}{8}$ "H
Net Volume	42.5 cu. ft.
Net Weight	437 lb.
Gross Weight	480 lb.
Packaging Dimensions	54 $\frac{1}{4}$ "W x 33"D x 84 $\frac{1}{2}$ "H

Cooling

Temperature Range	33°F-40°F
Refrigerant	R290
Max. Ambient Temperature	90
Defrosting	Automatic
Temperature Controller	Digital
Horsepower	1/4

Construction

Exterior Material	Black or white Coated Steel
Interior Material	Painted Aluminum
Door Type	Glass Swing
Insulation Material	Foamed-In-Place Polyurethane
Shelf Size	(8) 24 $\frac{3}{8}$ " x 23 $\frac{5}{8}$ "
Shelf Material	Plastic-Coated Steel
Shelf Load Capacity	90 lb.

Electrical

Voltage	115
Amps	4.5
Hz	60
Phase	1
Plug Type	NEMA 5-15P
Electrical Cord Length	96"

PLAN VIEW

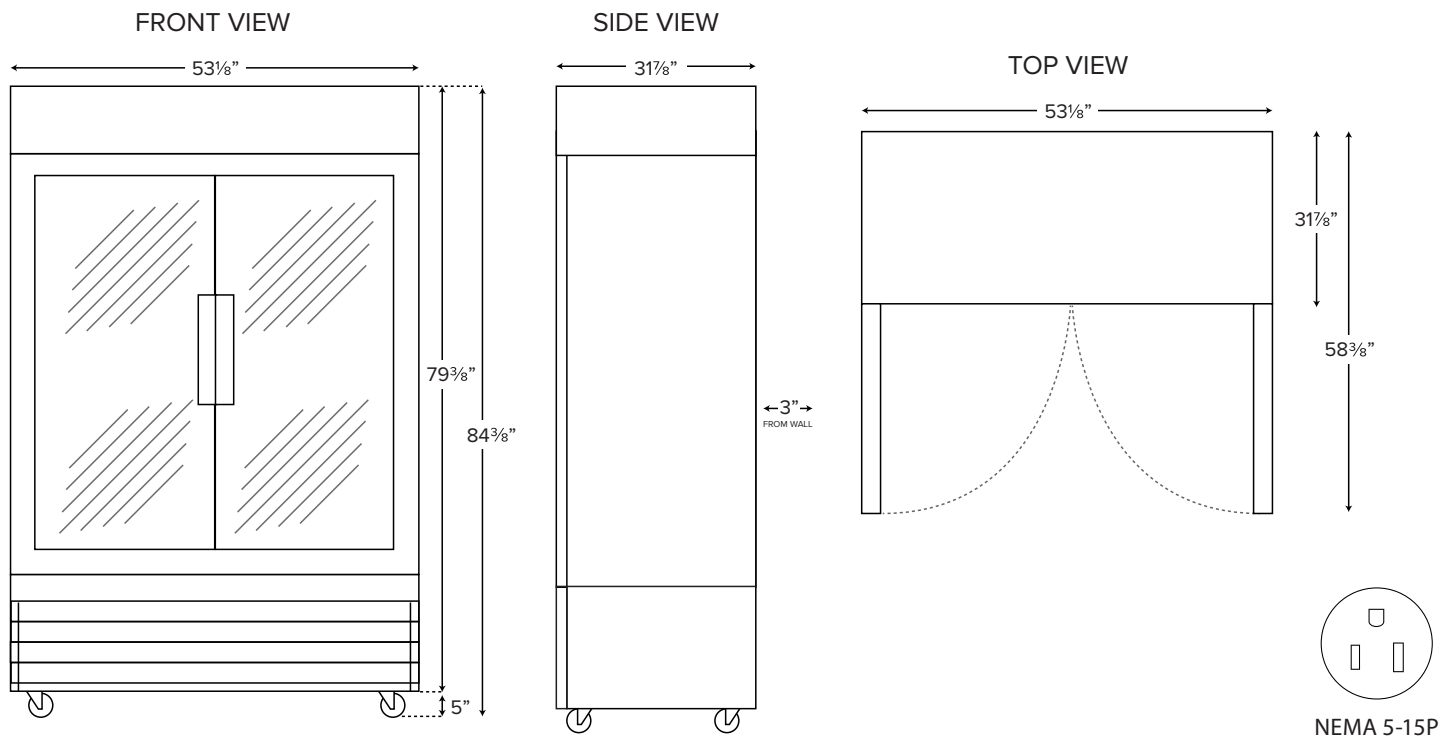



www.AvantcoRefrigeration.com

PROJECT: _____

MODEL: _____

ITEM #: _____ QUANTITY: _____

APPROVAL: _____ DATE: _____

GDC Series Glass Door Merchandisers

MODEL #178GDC49FHCW, #178GDC49FHCB

GDC SERIES - GLASS DOOR FREEZER

Used for the merchandising and storage of hermetically sealed food and beverages for sale.

CABINET CONSTRUCTION

Heavy duty construction includes black or white-coated aluminum interior walls and stainless steel floor. Exterior features peel and chip-resistant, powder-coated cold rolled steel that is durable and permanent.

Foamed-in-place polyurethane insulation enhances the structural strength of the cabinet and helps increase energy efficiency.

One-piece grill is easily removed for cleaning and servicing. 2 dual-pane tempered glass doors self-closes to save energy.

REFRIGERATION SYSTEM

Environmentally-safe R290 refrigerant. Bottom-mounted condensing unit positioned for easy maintenance. "No stoop" lower shelf maximizes visibility by raising merchandised product to a higher level.

SHELVING

8 plastic coated steel shelves included. Each are adjustable and accommodate up to 90 lb.

MODEL FEATURES

Copper evaporator coil eliminates the potential of corrosion. Convenient clean-out drain built into cabinet floor. Features built-in automatic defrost. Digital controller features auto-defrost function. LED lighted interior saves energy by producing less heat and maximizes product visibility in display area.

SPECIAL FEATURES

- Eco-friendly R290 hydrocarbon refrigerant
- 2 self-closing, glass swing doors
- 8 epoxy-coated steel shelves each holds up to 90 lb. of weight
- Bright, LED lighting
- Maintains temperatures between (-8)°F and (-1)°F
- Easy-to-use, digital temperature controls
- Foamed-in-place polyurethane insulation
- Black or white coated steel exterior and painted aluminum interior
- Stainless steel floor
- Available in black or white powder-coated steel exterior
- Auto defrost for easy maintenance
- 115V, 1/4 hp



WARRANTY

RESIDENTIAL: Avantco assumes no liability for parts or labor coverage for component failure, factory defect or any other damages for units installed in non-commercial foodservice or residential applications.



10/2019



GDC Series Glass Door Merchandiser

MODELS #178GDC49FHCW, #178GDC49FHCB



www.AvantcoRefrigeration.com

TECHNICAL DATA

Dimensions

Exterior Dimensions	53 $\frac{1}{8}$ "W x 31 $\frac{7}{8}$ "D x 84 $\frac{3}{8}$ "H
Interior Dimensions	50"W x 28 $\frac{3}{8}$ "D x 61 $\frac{7}{8}$ "H
Net Volume	42.5 cu. ft.
Net Weight	437 lb.
Gross Weight	480 lb.
Packaging Dimensions	54 $\frac{1}{4}$ "W x 33"D x 84 $\frac{1}{2}$ "H

Cooling

Temperature Range	(-8) [°] F - (-1) [°] F
Refrigerant	R290
Max. Ambient Temperature	90
Defrosting	Automatic
Temperature Controller	Digital
Horsepower	1/4
BTU (btu/hr)	2545

Construction

Exterior Material	Black or white Coated Steel
Interior Material	Painted Aluminum
Door Type	Glass Swing
Insulation Material	Foamed-In-Place Polyurethane
Shelf Size	(8) 24 $\frac{3}{8}$ " x 23 $\frac{5}{8}$ "
Shelf Material	Plastic-Coated Steel
Shelf Load Capacity	90 lb.

Electrical

Voltage	115
Amps	10.5
Hz	60
Phase	1
Plug Type	NEMA 5-15P
Electrical Cord Length	96"

PLAN VIEW

