

Avantco EF40-208-3 40 lb. Electric Floor Fryer - 208V, 3 Phase

Item #177EF40C



Technical Data

Width	15 1/2 Inches
Depth	28 Inches
Height	44 3/8 Inches
Fry Pot Width	13 3/4 Inches
Fry Pot Depth	13 3/4 Inches
Amps	34 Amps
Hertz	60 Hertz
Phase	3 Phase
Voltage	208 Volts
Wattage	12 Kilowatts
Application	Medium Duty
Burner Style	Open Pot
Capacity	40 lb.
Number of Fry Baskets	2 Fry Baskets
Number of Fry Pots	1 Fry Pots
Plug Type	Hardwire
Power Type	Electric
Type	Electric Floor Fryers

Features

- 40 lb. fry pot with efficient and affordable 12kW heating elements
- Two twin baskets provide flexibility; 13 3/4" x 13 3/4" frying area
- Extra-wide cold zone traps sediment to conserve oil and reduce flavor transfer
- Built-in thermostat reacts and adjusts to varying load capacities
- Fully submersed elements offer superior heat absorption to lower energy costs; 208V, 3 phase

Certifications



Hardwired



ETL US & Canada



ETL Sanitation

Plan View

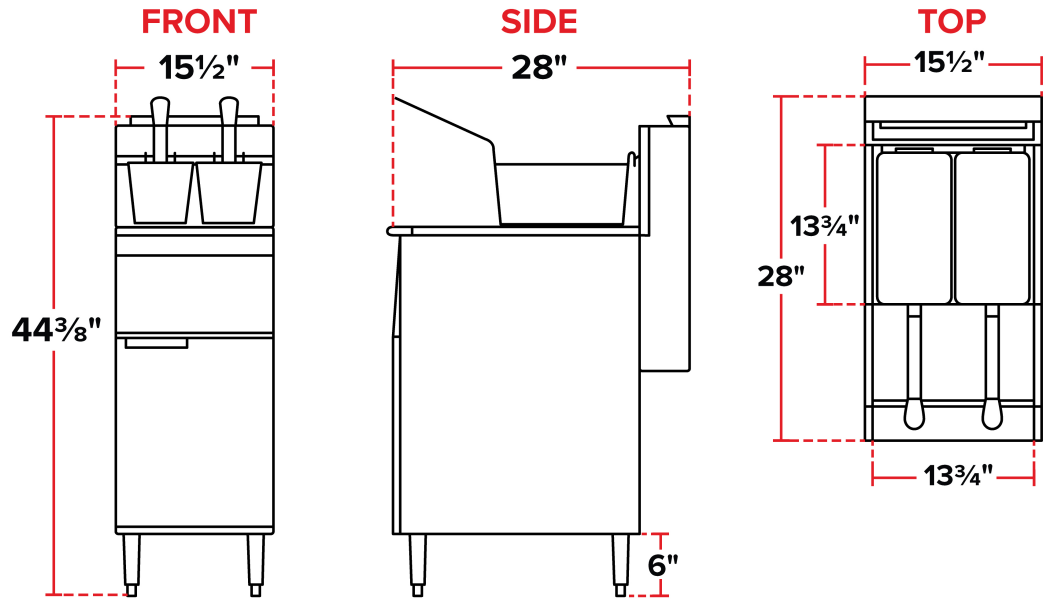

Notes & Details

Designed to maximize efficiency while ensuring simplicity, this Avantco EF40-208-3 40 lb. electric floor fryer provides all purpose, affordable frying in any kitchen! By maintaining full contact with the oil, the fryer's fully submersed elements provide superior heat absorption, which reduces recovery time and lowers overall energy consumption per pound of food. Not only does this save your staff valuable time during the dinner rush, but it also saves you money and increases profit margins.

Its extra-wide cold zone traps sediment below the cooking area, which helps conserve oil and reduces flavor contamination. The fryer's sloped bottom and drain pipe allow for quick, easy cleaning and maintenance. Plus, it features a stainless steel frypot, door, and backsplash, along with durable aluminized sides to stand up to the daily demands of your busy commercial kitchen. A built-in thermostat reacts and adjusts quickly to varying load capacities.

Get started frying right away with the included two fryer baskets! With an iron nickel coating, these baskets will withstand extreme temperatures in addition to preventing your fried foods from sticking to the bottom. This allows you to deep fry chicken wings, french fries, mozzarella sticks, or jalapeno poppers to golden perfection. Plus, the powder-coated green handle protects your staff from the heat and ensures they touch only the cool surface. This unit requires a 208V, 3 phase electrical connection.

⚠ WARNING: This product can expose you to chemicals including lead, which are known to the State of California to cause cancer, birth defects, or other reproductive harm. For more information, go to www.p65warnings.ca.gov.