

Item #: 177SS30VKIT Project: _____

Qty: _____ Date: _____ Approval: _____



Avantco SS-30VKIT 30 lb. Stainless Steel Vertical Hybrid Electric or Manual Sausage Stuffer with 1/2", 3/4", 1 1/4", and 1 1/2" Stainless Steel Funnels - 120V

Item #177SS30VKIT

Avantco Equipment



Technical Data

Length	22 13/16 Inches
Width	15 3/8 Inches
Height	30 11/16 Inches
Phase	1 Phase
Voltage	120 Volts
Capacity	30 lb.
Material	Stainless Steel
Plug Type	NEMA 5-15P
Power Type	Electric Manual
Type	Vertical Sausage Stuffers
Usage	Heavy Duty

Features

- 30 lb. stainless steel sausage stuffer with a vertical design that saves counter space
- Type 201 stainless steel sides; type 304 stainless steel canister for durability and easy cleaning
- Foot pedal promotes hands-free operation; heavy-duty pressure release valve for ultimate precision
- Includes 1/2", 3/4", 1 1/4", and 1 1/2" stainless steel funnels for a variety of products
- Hybrid design allows for operation as electric unit, saving time and labor

Certifications



Plan View

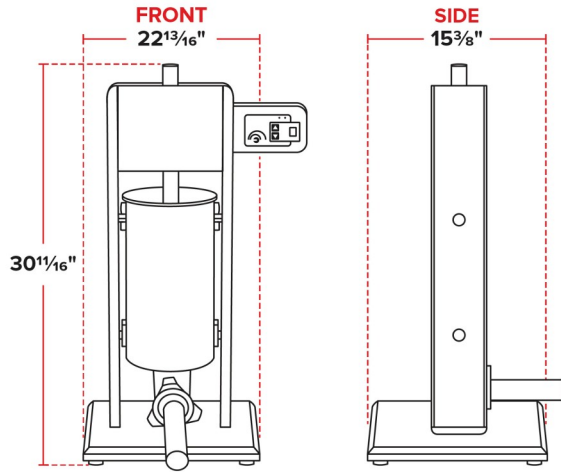

Notes & Details

Make kielbasa, chorizo, bratwurst, and other mouthwatering meats with this Avantco SS-30VKIT 30 lb. hybrid electric or manual sausage stuffer with 1/2", 3/4", 1 1/4", and 1 1/2" stainless steel funnels! This unit boasts a vertical design that delivers reliable performance while taking up minimal counter space. It includes 1/2", 3/4", 1 1/4", and 1 1/2" stainless steel funnels so you can make snack sticks, sausage, and luncheon meats without needing to buy any additional accessories. The four sizes of funnels allows you to use nearly infinite sizes of collagen, fibrous, and natural casings to make your special dishes.

The stuffer has enclosed steel gears that turn with two speed options so you can easily attach the handle to a fast-or-slow-turning shaft, combining with a pressure relief valve to offer precise control over your product's consistency. The handle and gear design give you greater leverage and make turning and stuffing sausage easier than ever. Large all-metal drive gears and piston rod are made to deliver the pressure needed to stuff sausages big and small, with ultimate control and consistency thanks to the built-in pressure valve. Plus, the heavy-duty gasket completely seals the cylinder to prevent any meat or air leaks that would compromise the perfect sausage.

Plus, the motor on this unit increases efficiency and saves your staff time and labor. With variable speed control, you can adjust the settings based on the texture and thickness of your sausage mixture. The motor controls the direction of the sausage and automatically reverses when it hits the bottom of the sausage stuffer. This eliminates all work associated with turning the handle manually, ensuring all employees can operate the unit with little to no exertion. The motor also includes a foot pedal for convenience, allowing the operator to instead focus on forming the sausage with their hands, eliminating the need to manually operate the unit. The hands-free design promotes sanitation, which is especially important in a kitchen that works with raw meats.

Type 201 stainless steel sides and a removable type 304 stainless steel tilt out canister ensure long-lasting durability as well as quick and simple cleaning. This sausage stuffer features large rubber feet and a heavy base to help prevent rocking during use. Add this rugged, large capacity sausage stuffer to your commercial kitchen or butcher shop to expand your sausage selection! This unit requires a 120V electrical connection for operation as electric stuffer.

⚠ WARNING: This product can expose you to chemicals including lead, which are known to the State of California to cause cancer, birth defects, or other reproductive harm. For more information, go to www.p65warnings.ca.gov.