



Item #: 177SAL23M Project: \_\_\_\_\_

Qty: \_\_\_\_\_ Date: \_\_\_\_\_ Approval: \_\_\_\_\_

## Avantco SAL23M 23" Electric Countertop Salamander - 208/240V, 3450/4000W

Item #177SAL23M

Avantco Equipment



### Technical Data

Width	23 3/4 Inches
Depth	20 1/2 Inches
Height	21 Inches
Power Cord Length	55 1/8 Inches
Cooking Area Width	23 1/4 Inches
Cooking Area Depth	12 1/2 Inches
Cooking Area Height	2 1/4 - 7 3/4 Inches
Amps	16.7 Amps
Phase	1 Phase
Voltage	208/240 Volts

### Features

- Spacious 23 1/4" x 12 1/2" cooking area for a variety of dishes, plate, and platter sizes
- Durable stainless steel construction with heat reflectors and cool-touch handle on the upper housing
- Versatile applications with removable stainless steel drip tray and cooking grate included
- Engraved 1-5 height markings on the back wall for consistent cooking results
- (2) Infinite controls and (2) audible 15 minute timers for easy operation; 208/240V, 3450/4000W

### Certifications

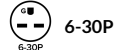
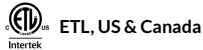

## Technical Data

Wattage	3450/4000 Watts
Control Type	Infinite
Installation Type	Countertop
Number of Shelves	1 Shelf
Plug Type	NEMA 6-30P
Power Type	Electric
Timer	With Timer
Type	Salamanders

## Plan View

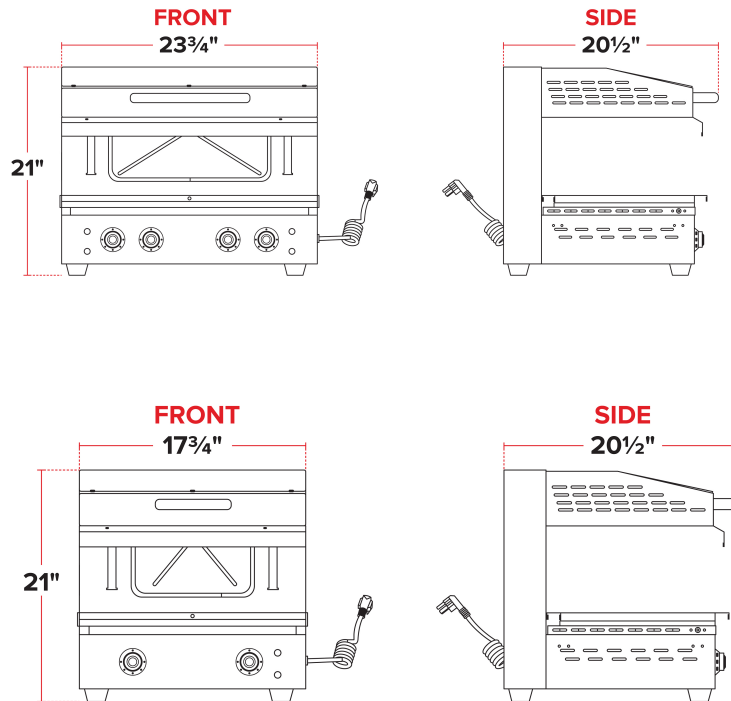

## Notes & Details

Cook protein, finish off an entree, melt cheese on nachos or french onion soup, toast bread, or caramelize creme brulee with this Avantco SAL23M 23" electric countertop salamander! This salamander's compact and versatile design is perfect for your high volume restaurant or bar. Since this model has a 23 1/4" x 12 1/2" cooking area and an adjustable 2 1/4" to 7 3/4" cooking clearance, it can accept a large variety of pan and plate sizes for appetizers, signature dishes, or desserts. Also, the adjustable upper housing has laser engraved height markings from 1-5 on the back wall for dependable, consistent cooking results. Cool touch bakelite handles make it easy to adjust the position of the elements and cooking tray.

This salamander is made of heavy-duty stainless steel for greater durability in fast-paced kitchens. The polished reflectors on the upper housing help to reflect heat toward the cooking area, ensuring food is properly cooked and kept warm while waiting to be served to customers. Two independently controlled heating elements include sets of infinite controls that are easy to use, providing ideal control heating cycles, and creating the perfect outcome for every individual dish. It has 2 separate 15 minute audible timers to help ensure consistent cooking results for different dishes.

A stainless steel removable drip tray and a cooking grate are included to make cleaning as easy as possible and to add versatility to the uses of this salamander. Add a cast iron griddle (sold separately) for even more options! Non-slip rubber feet ensure the salamander will stay stable on your countertop. This model requires a 208/240V, 3450/4000W electrical connection for operation and includes a 55 1/8" power cord.



**⚠ WARNING:** This product can expose you to chemicals including lead, which are known to the State of California to cause cancer, birth defects, or other reproductive harm. For more information, go to [www.p65warnings.ca.gov](http://www.p65warnings.ca.gov).

Avantco Equipment