



Item #: 177SAL17M Project: _____

Qty: _____ Date: _____ Approval: _____

Avantco SAL17M 17" Electric Countertop Salamander - 208/240V, 2290/3050W

Item #177SAL17M



Technical Data

Width	17 3/4 Inches
Depth	20 1/2 Inches
Height	21 Inches
Power Cord Length	55 1/8 Inches
Cooking Area Width	17 1/4 Inches
Cooking Area Depth	12 1/2 Inches
Cooking Area Height	2 1/4 - 7 3/4 Inches
Amps	13.7 Amps
Phase	1 Phase
Voltage	208/240 Volts

Features

- Spacious 17 1/4" x 12 1/2" cooking area for a variety of dishes, plate, and platter sizes
- Durable stainless steel construction with heat reflectors and cool-touch handle on the upper housing
- Versatile applications with removable stainless steel drip tray and cooking grate included
- Engraved 1-5 height markings on the back wall for consistent cooking results
- Infinite controls and audible 15 minute timer for easy operation; 208/240V, 2290/3050W

Certifications



Avantco Equipment

Technical Data

Wattage	2290/3050 Watts
Control Type	Infinite
Installation Type	Countertop
Number of Shelves	1 Shelf
Plug Type	NEMA 6-20P
Power Type	Electric
Timer	With Timer
Type	Salamanders

Plan View

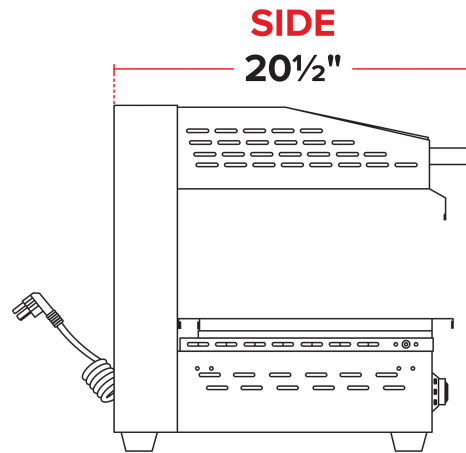
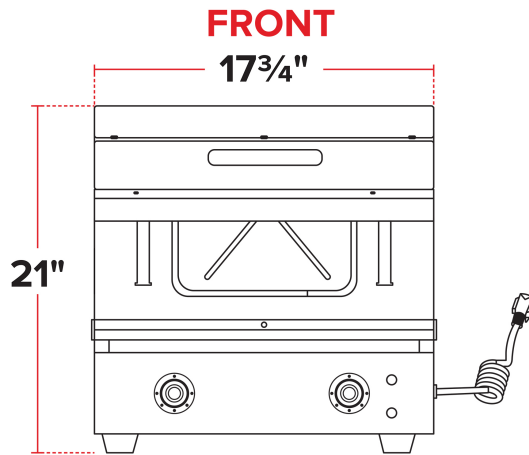



Notes & Details

Cook protein, finish off an entree, melt cheese on nachos or french onion soup, toast bread, or caramelize a creme brulee with this Avantco SAL17M 17" electric countertop salamander! This salamander's compact and versatile design is perfect for your small to medium-sized restaurant or bar. Since this model has a 17 1/4" x 12 1/2" cooking area and an adjustable 2 1/4" to 7 3/4" cooking clearance, it can accept a large variety of pan and plate sizes for appetizers, signature dishes, or desserts. Also, the adjustable upper housing has laser engraved height markings from 1-5 on the back wall for dependable, consistent cooking results. Cool touch bakelite handles make it easy to adjust the position of the elements and cooking tray without injury.

This salamander is made of heavy-duty stainless steel for greater durability in fast-paced kitchens. The polished reflectors on the upper housing help to reflect heat toward the cooking area, ensuring food is properly cooked. Infinite controls are easy to use, providing ideal control over the heating cycles, and creating the perfect outcome for every individual dish. Also, it has a 15 minute audible timer to help ensure consistent cooking results.

A stainless steel removable drip tray and a cooking grate are included to make cleaning as easy as possible and to add versatility to the uses of this salamander. Add a cast iron griddle (sold separately) for even more options! Non-slip rubber feet ensure the salamander will stay stable on your countertop. This model requires a 208/240V, 2290/3050W electrical connection for operation and includes a 55 1/8" power cord.

⚠ WARNING: This product can expose you to chemicals including lead, which are known to the State of California to cause cancer, birth defects, or other reproductive harm. For more information, go to www.p65warnings.ca.gov.