



Item #: 177IC35SU Project: _____

Qty: _____ Date: _____ Approval: _____

Avantco IC35SU Stainless Steel Double Countertop Step-Up Induction Range / Cooker - 208-240V, 3600W

Item #177IC35SU

Avantco Equipment



Technical Data

Width	13 3/8 Inches
Depth	29 15/16 Inches
Height	6 3/8 Inches
Cooking Surface Diameter	4 3/4 - 10 1/4 Inches
Recommended Pan Size (Bottom Diameter)	8 Inches
Hertz	60 Hertz
Phase	1 Phase
Voltage	208 - 240 Volts
Wattage	3600 Watts
Color	Red

Features

- Fast, flameless heat provides easy cooking with reduced injury risk
- Independently operating burners with step-up design saves space and keeps employees safe
- Adjustable timer can be set for up to 180 minutes; 9 available power levels
- Durable stainless steel body with 110 lb. suggested weight capacity
- Automatically switches to standby mode when pan is removed; 10 1/4" max bottom pan

Certifications



Technical Data

Burner Orientation	Front to Back Step Up
Control Type	Digital
Features	Timer
Installation Type	Countertop
Number of Burners	Burners Double
Number of Power Levels	9
Plug Type	NEMA 6-20P
Power Type	Electric
Suggested Weight Capacity	110 lb.
Temperature Range	140 - 460 Degrees F
Type	Heaters Induction Ranges
Usage	Front of House

Plan View

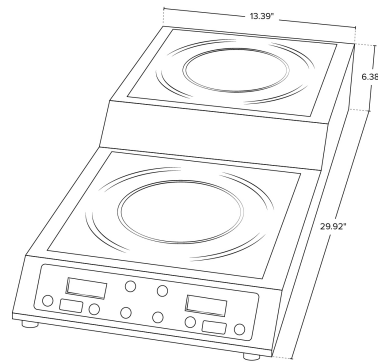



Notes & Details

Bring convenience, safety, and portability to your food service with the help of this Avantco IC35SU stainless steel double countertop step-up induction range / cooker. This compact, lightweight unit is an ideal choice for front of the house cooking demonstrations or sampling. Perfect for medium-duty use in omelet or pasta stations, catering services, display cooking, or anywhere you need extra burner space, this induction range provides a level of safety that surpasses traditional burners. The surface of the range only heats the bottom of induction-ready cookware and does not retain heat, making it safer for use around guests. The heat energy absorbs immediately into the cookware, allowing you to cook food quickly and efficiently. When you remove the cookware, the burners enter standby mode and will not create a hot surface. Using this countertop range is easy and user-friendly thanks to two heat adjustment modes. You can choose between adjusting the power level of the burners from 1 to 9, or delicately adjust each burner's temperature to find the perfect heat between 140 and 460 degrees Fahrenheit.

Each burner packs 1800W of power to create a total of 3600W, so you can boil water on one burner and cook protein or sauces on the other with ease. This range includes a timer for easy, controlled cooking that reaches up to 180 minutes measured in 5-minute increments. The unit's 9 power levels ensure you can use it for everything, from simmering sauces to searing steaks. Its durable stainless steel body ensures its durability to withstand consistent use at events and special occasions, while its flameless heat provides fast, efficient cooking and reduces the risk of injuries.

The step-up design provides two usable burners while remaining compact and providing an ergonomic design to keep your employees safe, making this unit perfect for events where space is limited. It accommodates pots between 4 3/4" and 10 1/4" in diameter and requires a 240V electrical connection for operation.

⚠ WARNING: This product can expose you to chemicals including lead, which are known to the State of California to cause cancer, birth defects, or other reproductive harm. For more information, go to www.p65warnings.ca.gov.