



Item #: 177FB1366 Project: \_\_\_\_\_

Qty: \_\_\_\_\_ Date: \_\_\_\_\_ Approval: \_\_\_\_\_

## Avantco 177FB1366 13 1/4" x 6 1/2" x 5 7/8" Fryer Basket with Front Hook for FF40, FF50, FF300, and FF400

Item #177FB1366



### Technical Data

Length	13 1/4 Inches
Width	6 1/2 Inches
Height	5 7/8 Inches
Color	Silver
Handle Color	Black
Handle Type	Coated
Material	Stainless Steel
Shape	Rectangle
Type	Floor Fryer Baskets

### Features

- Fits Avantco 40 lb. and 50 lb. floor fryers
- Durable wire mesh design
- Front hook fits on a basket hanger rail for convenient draining
- Coated handle protects employees from burns
- Durable construction for long lasting use

Avantco Equipment

## Plan View

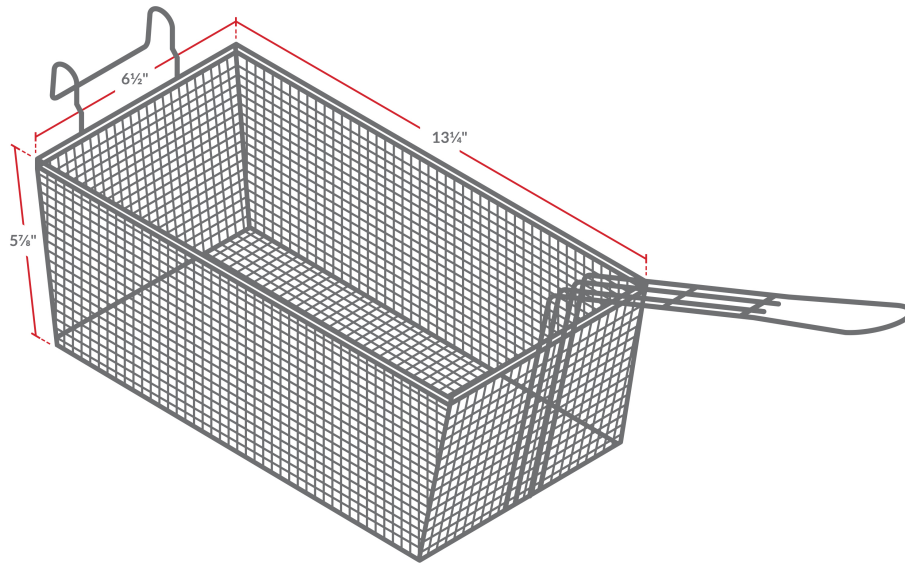

## Notes & Details

Replace a damaged fry basket or keep an extra one on hand with this Avantco 177FB1366 fryer basket with a front hook. A perfect fit for your Avantco 40 lb. or 50 lb. floor fryer, this basket lets you efficiently fry up portions of french fries, chicken fingers, popcorn shrimp, deep-fried pickles, and more! Use this basket to replace a broken one, or keep an extra basket on hand for the times when you need a clean basket.

With a durable wire design, this basket keeps food suspended in hot oil for even cooking on all sides, but then allows the oil to quickly drain away after cooking. The front hook fits over a basket hanger rail, so you can make sure all excess oil drains off your fresh fried foods before you serve them. Plus, the coated handle provides a cooler grip that protects employees from burns.

**⚠ WARNING:** This product can expose you to chemicals including lead, which are known to the State of California to cause cancer, birth defects, or other reproductive harm. For more information, go to [www.p65warnings.ca.gov](http://www.p65warnings.ca.gov).