



Item #: 177EG48N Project: \_\_\_\_\_

Qty: \_\_\_\_\_ Date: \_\_\_\_\_ Approval: \_\_\_\_\_

## Avantco EG48N 48" Electric Countertop Griddle - 208/240V, 10482W-14000W

Item #177EG48N



### Technical Data

Width	48 3/16 Inches
Depth	25 Inches
Height	15 3/4 - 17 3/4 Inches
Cooking Surface Width	48 Inches
Cooking Surface Depth	20 1/2 Inches
Phase	1 Phase
Voltage	208/240 Volts
Wattage	10.482 - 14 Kilowatts
Control Type	Thermostatic
Cooking Surface Material	Polished Steel

### Features

- 20" x 48" cooking area is great for breakfast food, vegetables, or meat
- 1" thick steel cooking surface creates even and consistent heat with quick recovery
- Four independent zones with adjustable temperature ranges of 150-570 degrees Fahrenheit
- Large 3" steel splashguards on sides and back, two large 1L grease trays for easy cleanup
- 208/240V, 1 Phase; 10482W-14000W

### Certifications



ETL Sanitation



Hardwired



ETL, US & Canada

Avantco Equipment

## Technical Data

Features	Adjustable Height Side Splashes
Grease Tray Size	1 Liters
Installation Type	Countertop
Number of Burners	3 Burners
Number of Controls	4 Controls
Plate Thickness	1 Inch
Plug Type	Hardwire
Power Type	Electric
Temperature Range	150 - 570 Degrees F
Temperature Settings	Adjustable
Type	Griddles
Usage	Standard Duty

## Plan View

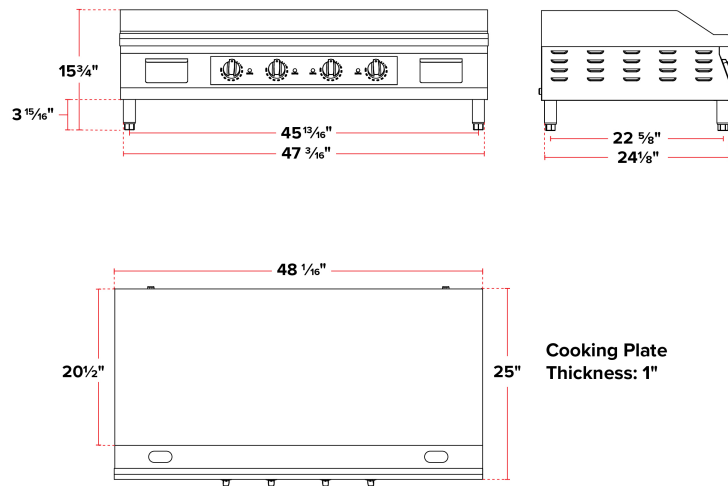

## Notes & Details

The Avantco EG48N electric countertop griddle allows operators to prepare various foods in a 48" footprint. Whether you're cooking pancakes, burgers, grilled cheese, or scrambled eggs, this heavy-duty stainless steel griddle provides the durability and performance you need to get the job done.

The 1" thick steel cooking surface heats evenly throughout for consistent cooking results, no matter where you place food on the griddle plate. And with 4 separate temperature knobs, overheat protection, and power on / heating indicator lights, this griddle is as safe to use as it is powerful and effective. The 3" splash guards on the sides and back of the griddle also protect the user and surrounding walls from hot grease and oil splatters.

The stainless steel legs that come with this griddle are adjustable from 3 15/16" to 5 15/16" to provide stability on any surface. A channel along the front of the griddle plate collects grease and directs it into the removable grease tray. When it's time to clean up, the tray can be removed and emptied quickly. Four separate thermostatic controls allow you to adjust the temperature to suit the cooking requirements of different foods. This prevents you from burning one product while others finish cooking.

**⚠ WARNING:** This product can expose you to chemicals including lead, which are known to the State of California to cause cancer, birth defects, or other reproductive harm. For more information, go to [www.p65warnings.ca.gov](http://www.p65warnings.ca.gov).