



Item #: 177CO28M Project: _____

Qty: _____ Date: _____ Approval: _____

Avantco CO-28M Half Size Countertop Convection Oven, 2.3 cu. ft. - 208/240V, 2100/2800W

Item #177CO28M



Technical Data

Width	23 Inches
Depth	22 1/2 Inches
Height	20 Inches
Power Cord Length	71 Inches
Interior Width	18 1/2 Inches
Interior Depth	16 Inches
Interior Height	14 Inches
Voltage	208/240 Volts
Capacity	2.3 cu. ft.
Control Type	Dial

Features

- Half size interior holds up to (4) 1/2 size sheet pans and has extra spacing between racks for taller
- Fully adjustable heat settings from 150-550 degrees Fahrenheit to cook a variety of dishes and foods
- Cool-touch dual pane glass door keeps the heat inside while checking on the cooking progress
- Durable stainless steel construction and 4" stainless steel feet for improved airflow and easy clean
- Ideal for light-volume baking; 208/240V, 2100/2800W, 2.3 cu. ft.

Certifications

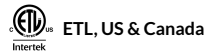
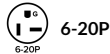

Avantco Equipment

Technical Data

Wattage	2.1 Kilowatts 2.8 Kilowatts 2100 Watts 2800 Watts
Door Type	Glass
Hinge Location	Bottom
Installation Type	Countertop
Number of Controls	2 Controls
Number of Doors	1 Doors
Number of Shelves	4 Shelves
Oven Interior Style	Standard Depth
Oven Shelf Spacing	2 3/4 Inches
Plug Type	NEMA 6-20P
Power Type	Electric
Rack Capacity	4
Size	Half Size
Temperature Range	150 - 550 Degrees F
Temperature Settings	Adjustable

Plan View

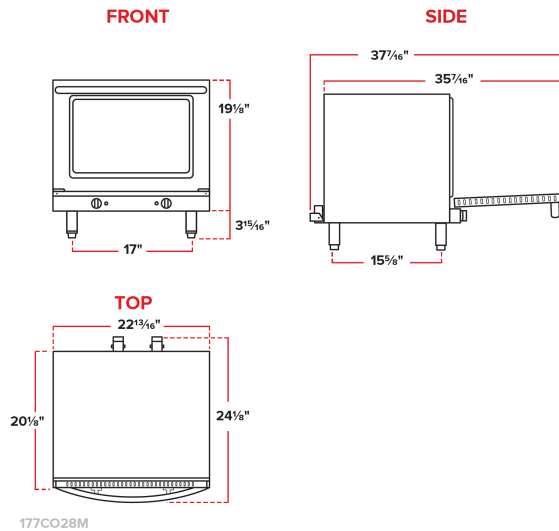



Notes & Details

Cost-effective and versatile, this Avantco CO-28M countertop convection oven is great for supplemental baking, low-volume baking, and medium-volume reheating at coffee shops, kiosks, churches, and schools. Its half size cavity can handle up to (4) half size 13" x 18" sheet pans while its compact design is great for small footprint and countertop needs with a recommended approximate usage of 4 hours per day, 5 days per week. Note: this unit is not intended for high-volume, high-temperature, or delicate baking requirements. Please see operation manual.

Powered by 2,100/2,800W, the unit is equipped with two dial controls for adjusting the temperature between 150 and 550 degrees Fahrenheit and for setting the audible timer from 1 to 120 minutes, respectively. Each dial is accompanied by an indicator light too, which alerts the user to when each function is in operation. As the oven produces heat, dual convection fans work to spread the heat evenly around the cavity to ensure efficient and thorough cooking or baking. This oven includes a master on/off switch, which allows the user to turn off the unit without changing the temperature dial control.

Because the window in the door is tempered dual-pane glass, it allows employees to easily keep an eye on food while it's cooking. The door's improved hinge design is built to last through thousands of openings and closings. This, along with the full border gasket, helps seal-in heat and reduce risk of injury. Plus, the door's full-length, cool-touch handle provides easy oven access. Inside, the oven features a set of 4 wire shelves, which are adjustable to best accommodate your ever-changing tasks. Shelves can even be added and removed to accommodate multiple sheet pans or a single roast pan.

Made with a stainless steel interior, the oven cavity won't corrode or rust, even with the accidental spill or leak. The exterior of the oven, also made of stainless steel, provides overall durability for coffee shops and kiosks. To abide by food safety guidelines, the unit is equipped with 4" stainless steel legs, which raise the oven off of the countertop surface below for improved airflow and easy cleaning. A 208/240V electrical connection is required for operation.

⚠ WARNING: This product can expose you to chemicals including lead, which are known to the State of California to cause cancer, birth defects, or other reproductive harm. For more information, go to www.p65warnings.ca.gov.