

Avantco CO-16 Half Size Countertop Convection Oven, 1.5 Cu. Ft. - 120V, 1600W

Item #177CO16



Technical Data

Width	23 Inches
Depth	22 1/2 Inches
Height	16 1/2 Inches
Power Cord Length	71 Inches
Interior Width	18 1/2 Inches
Interior Depth	14 1/2 Inches
Interior Height	9 3/4 Inches
Amps	13.3 Amps
Hertz	60 Hertz
Phase	1 Phase

Features

- 1/2 size interior holds up to (4) 1/2 size sheet pans on included wire shelves or using guides
- Fully adjustable heat settings from 150-500°F to cook a variety of dishes and foods
- Cool-touch dual pane glass door keeps the heat inside while checking on the cooking progress
- Heavy-duty stainless steel construction for easy cleaning
- Ideal for light-duty use; 120V, 1600W, 1.5 cu. ft.

Certifications



Technical Data

Voltage	120 Volts
Wattage	1.6 Kilowatts 1600 Watts
Capacity	1.5 cu. ft.
Control Type	Dial
Door Type	Glass
Hinge Location	Bottom
Installation Type	Countertop
Number of Chambers	1 Chambers
Number of Controls	2 Controls
Number of Doors	1 Doors
Oven Interior Style	Standard Depth
Oven Shelf Spacing	1 7/16 Inches
Plug Type	NEMA 5-15P
Power Type	Electric
Rack Capacity	4
Size	Half Size
Temperature Range	150 - 500 Degrees F
Temperature Settings	Adjustable

Plan View

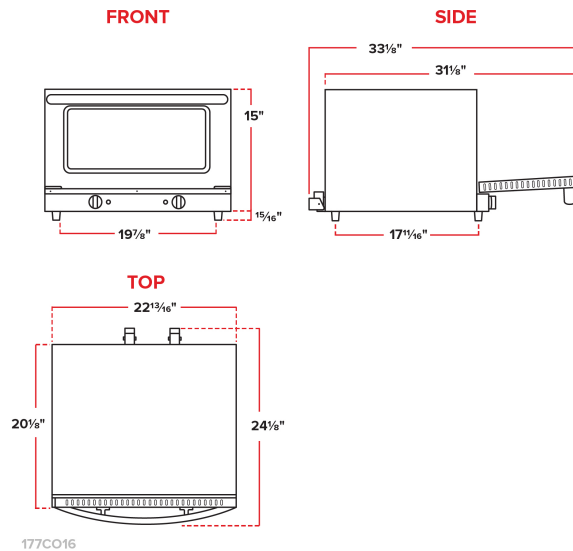

Notes & Details

If you need more cooking flexibility with limited space requirements, the Avantco CO-16 half size convection oven is a great way to make pizzas, baked goods, snacks, warm sandwiches and more right on your countertop. This 1.5 cu. ft. oven boasts 1600 watts of heating power and forced-air heat circulation for even cooking, and can hold up to four, 1/2 size sheet pans at one time. Four chrome wire shelves are included so you can begin baking right away! Plus, cooking temperature can be adjusted up to 500 degrees Fahrenheit, and a built-in 120 minute timer lets you know when food is cooked to perfection.

This oven's interior and exterior are fully constructed of heavy duty stainless steel, and the cool-touch dual pane glass door window keeps heat in while preventing operator burns on the exterior side. A vent with guard is located at the rear of the unit for even heat and air distribution. The Avantco CO-16 requires a 120V electrical connection for operation.



⚠ WARNING: This product can expose you to chemicals including lead, which are known to the State of California to cause cancer, birth defects, or other reproductive harm. For more information, go to www.p65warnings.ca.gov.

Avantco Equipment