

Avantco CHSME23M 23" Electric Countertop Cheese Melter - 208/240V, 1800/2400W

Item #177CHSME23IM



Technical Data

Width	23 Inches
Depth	15 1/4 Inches
Height	16 Inches
Power Cord Length	4 Feet
Rack Width	16 1/2 Inches
Rack Depth	13 1/4 Inches
Amps	10 Amps
Hertz	60 Hertz
Phase	1 Phase
Voltage	208/240 Volts

Features

- 16 1/2" x 13 1/4" rack fits a 12" plate or sizzle platter
- Full-width calrod heating elements and durable stainless steel construction with insulated body
- Compact countertop or wall-mount design for limited kitchen space
- 4 rack positions and removable food rack with 6" bakelite handles included
- Infinite controls and audible 15-minute timer for easy operation; 208/240V, 1800/2400W

Certifications



ETL Sanitation



6-20P



ETL, US & Canada

Technical Data

Wattage	1800/2400 Watts
Control Type	Infinite
Features	Timer
Heating Source	Metal Sheathed / Calrod
Installation Type	Countertop Wall Mounted
Material	Stainless Steel
Number of Shelves	1 Shelf
Plug Type	NEMA 6-20P
Power Type	Electric
Temperature Settings	Adjustable
Type	Cheese Melters
Usage	Standard Duty

Plan View

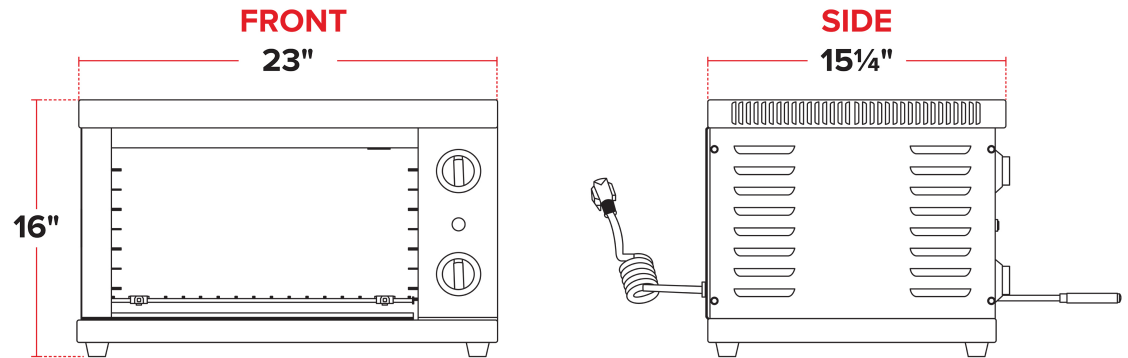

Notes & Details

Quickly melt cheese on nachos, toast roast beef sandwiches, or warm up plates with this Avantco CHSME23M 23" electric countertop cheese melter! Designed to help you quickly warm, toast, and melt appetizers, sandwiches, or small dishes, this versatile cheese melter is perfect for your medium-sized restaurant or bar. Since this model has a 16 1/2" x 13 1/4" rack, it can fit plates or sizzle platters with diameters of up to 12". The adjustable rack has 4 rack positions to meet the needs of different dishes. 6" cool-to-touch Bakelite handles make it easy to adjust or remove the food rack.

This cheese melter is made of heavy-duty stainless steel for greater durability in fast-paced kitchens. The insulated body ensures better heat retention, helping food stay warm and reducing recovery time. High, medium, and low infinite controls are easy to use, providing ideal control over heating cycles and creating the perfect outcome for every individual dish. It has a 15-minute audible timer to help ensure consistent cooking results.

A stainless steel removable crumb tray is included to make cleaning as easy as possible and to keep your unit free of crumbs and burnt pieces. This compact countertop model can also be wall-mounted with the included brackets to save even more counter space if desired. Non-slip rubber feet ensure the melter will stay stable on your countertop. This model requires a 208/240V electrical connection for operation and includes a 4' power cord.



⚠ WARNING: This product can expose you to chemicals including lead, which are known to the State of California to cause cancer, birth defects, or other reproductive harm. For more information, go to www.p65warnings.ca.gov.

Avantco Equipment