

Avantco Chef Series CAG-R-4-24 24" 4 Burner Gas Countertop Range - 100,000 BTU

Item #177CAGR424



Technical Data

Width	24 Inches
Depth	30 1/2 Inches
Height	16 7/8 Inches
Nominal Width	24 Inches
Cooking Height	13 1/8 Inches
Burner BTU	25000 BTU
Control Type	Manual
Features	Field-Convertible (Gas) Massachusetts Accepted Plumbing Product
Gas Connection Size	3/4 Inches

Features

- Durable stainless steel body withstands tough kitchen environments
- Standing pilots provide instant ignition for ease of use
- Capitalize on cooking space with 4 independent burners
- Field convertible to liquid propane; orifices included
- 100,000 BTU; 3/4" rear gas connection

Certifications



3/4" Gas Connection



UL Classified EPH



UL Listed, US & Canada



Field Convertible (Gas)

Technical Data

Installation Type	Countertop
Number of Burners	4 Burners
Number of Controls	4 Controls
Power Type	Natural Gas
Style	Standard
Total BTU	100000 BTU
Usage	Standard Duty

Plan View

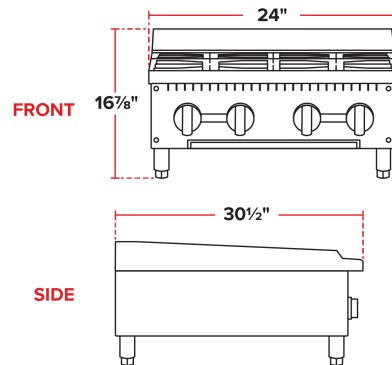

Notes & Details

Perfect for busy operations that are tight on space, this Avantco Chef Series gas 24" 4 burner countertop range adds easy compact convenience to your kitchen! With a countertop design, the unit is space efficient, and with its (4) 25,000 BTU burners, it's ideal for whipping up sauces, sides, entrees, and even desserts. Operation is simple and intuitive, thanks to the 4 large control knobs located on the front of the unit, while standing pilots are centered between the controls for ease of use. Its countertop design leaves room in your kitchen for additional equipment, supplies, or work surface area. It also allows placement on top of existing work tables and chef bases, ensuring that your space is maximized to its full potential.

Unlike other gas ranges that require liquid propane or natural gas, this unit can be converted to utilize either fuel type. It's also designed with a stainless steel exterior to withstand even the busiest of kitchen environments, ensuring that wherever it's used, it's sure to be a reliable addition to your cooking equipment repertoire.

Featuring a removable waste tray that makes clean-up quick and easy, the unit is outfitted with 4" legs that adjust to suit your needs. These lift the unit up from the countertop surface, making clean-up an easy task at the end of the day. The unit uses a total 100,000 BTU for operation. It ships ready for a natural gas connection, but is field convertible to accept liquid propane.

⚠ WARNING: This product can expose you to chemicals including lead, which are known to the State of California to cause cancer and birth defects or other reproductive harm. For more information, go to www.p65warnings.ca.gov.