



Item #: 177CAG60MG Project: _____

Qty: _____ Date: _____ Approval: _____

Avantco Chef Series CAG-60-MG 60" Countertop Gas Griddle with Manual Controls - 150,000 BTU

Item #177CAG60MG



Technical Data

Width	60 Inches
Depth	30 1/2 Inches
Height	16 13/16 Inches
Cooking Surface Width	60 Inches
Cooking Surface Depth	19 3/5 Inches
Burner BTU	30000 BTU
Control Type	Manual
Features	Field-Convertible (Gas) Massachusetts Accepted Plumbing Product
Gas Connection Size	3/4 Inches

Features

- 3/4" thick polished steel griddle plate for ample heat retention and reduced recovery time
- Capitalize on cooking space with 5 independent burners to allow for maximum productivity
- Standing pilots provide instant ignition for ease of use
- Durable stainless steel body withstands tough kitchen environments
- Field convertible to liquid propane; orifices included; 150,000 BTU; 3/4" rear gas connection

Certifications



3/4" Gas Connection



UL Classified EPH



UL Listed, US & Canada



Field Convertible (Gas)

Avantco Equipment

Technical Data

Griddle Location	Full Surface
Installation Type	Countertop
Number of Burners	5 Burners
Number of Controls	5 Controls
Plate Thickness	3/4 Inch
Power Type	Natural Gas
Temperature Settings	Adjustable
Total BTU	150000 BTU
Type	Griddles
Usage	Standard Duty

Plan View

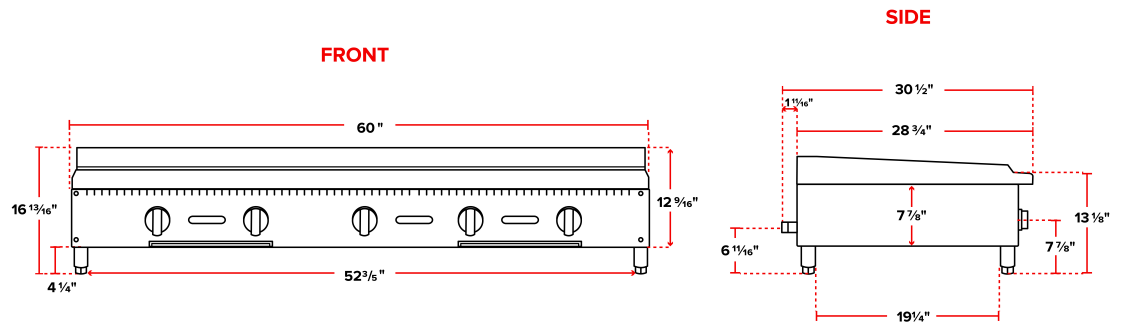

Notes & Details

Perfect for busy operations that are tight on space, this Avantco Chef Series 60" countertop gas griddle with manual controls adds easy compact convenience to your kitchen! The unit is space efficient, designed specifically for your kitchen countertop and allows you to maximize every inch of work space. With (5) 30,000 BTU burners, it is ideal for cooking burgers, pancakes, or vegetable skewers, as each burner can be set to a different temperature. For quality performance, the griddle surface is 3/4" thick, ensuring quick recovery and convenient heat retention, saving you money and keeping your kitchen cool.

With a countertop design, the unit is space efficient, leaving room in your kitchen for additional equipment, supplies, or work surface area. It also allows placement on top of existing work tables and chef bases, ensuring that your space is maximized to its full potential. For quick and easy cleaning, this unit features a waste tray to collect food particles. Simply remove the tray, empty or rinse it, and return it back to its original spot.

Operation is simple and intuitive, thanks to the 5 large control knobs located on the front of the unit. These controls operate the burners independently, so you can set each burner on the griddle to a different temperature and cook different items at the same time. Unlike other gas griddles that require liquid propane or natural gas, this unit ships ready for a natural gas connection, but can be converted to accept liquid propane. The unit uses a total 150,000 BTU for operation.

⚠ WARNING: This product can expose you to chemicals including lead, which are known to the State of California to cause cancer, birth defects, or other reproductive harm. For more information, go to www.p65warnings.ca.gov.