



Item #: 177CAG24RC Project: _____

Qty: _____ Date: _____ Approval: _____

Avantco Chef Series CAG-24-RC 24" Gas Countertop Radiant Charbroiler - 60,000 BTU

Item #177CAG24RC



Technical Data

Width	24 Inches
Depth	30 1/2 Inches
Height	16 13/16 Inches
Cooking Surface Width	24 Inches
Cooking Surface Depth	21 1/2 Inches
Base Style	Without Base
Burner BTU	30,000 BTU
Control Type	Manual
Features	Field-Convertible (Gas) Massachusetts Accepted Plumbing Product

Avantco Equipment

Features

- Capitalize on cooking space with 2 independent burners to allow for maximum productivity
- Uses cast iron radiants to deflect heat towards cooking surface
- Field convertible to liquid propane; orifices included
- Equipped with removable cast iron top grates for better flame control
- 60,000 BTU; 3/4" rear gas connection

Certifications



3/4" Gas Connection



UL Classified EPH



UL Listed, US & Canada



Field Convertible (Gas)

Technical Data

Gas Connection Size	3/4 Inches
Heating Source	Radiant
Installation Type	Countertop
Number of Burners	2 Burners
Number of Controls	2 Controls
Power Type	Natural Gas
Temperature Settings	Adjustable
Total BTU	60000 BTU
Type	Charbroilers
Usage	Medium Duty Standard Duty

Plan View

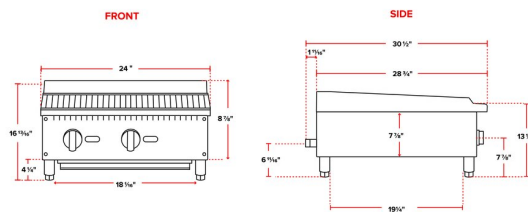

Notes & Details

Perfect for busy operations that are tight on space, this Avantco Chef Series CAG-24-RC 24" gas radiant charbroiler adds easy compact convenience to your kitchen! The unit is space efficient, designed specifically for your kitchen countertop and allows you to maximize every inch of work space. With (2) 30,000 BTU burners, it is ideal for grilling burgers on one side and shrimp on the other. For quality performance, this charbroiler uses radiants to deflect heat towards the cooking surface, ensuring quick recovery and convenient heat retention, saving you money and keeping your kitchen cool.

With a countertop design, the unit is space efficient, leaving room in your kitchen for additional equipment, supplies, or work surface area. It also allows placement on top of existing work tables and chef bases, ensuring that your space is maximized to its full potential. For quick and easy cleaning, this unit features a waste tray to collect food particles. Simply remove the tray, empty or rinse it, and return it back to its original spot.

Operation is simple and intuitive, thanks to the 2 large control knobs located on the front of the unit. These controls operate the burners independently, so you can set each side of the charbroiler to a different temperature and cook different items at the same time. Unlike other gas charbroilers that require liquid propane or natural gas, this unit ships ready for a natural gas connection, but can be converted to accept liquid propane. The unit uses a total 60,000 BTU for operation.

⚠ WARNING: This product can expose you to chemicals including lead, which are known to the State of California to cause cancer and birth defects or other reproductive harm. For more information, go to www.p65warnings.ca.gov.