

Item #: 177ACR22SS Project: \_\_\_\_\_

Qty: \_\_\_\_\_ Date: \_\_\_\_\_ Approval: \_\_\_\_\_

## Avantco ACR22SS 22 Qt. Countertop Roaster Oven / Warmer - 120V, 1450W

Item #177ACR22SS



### Technical Data

Width	23 3/8 Inches
Depth	15 1/2 Inches
Height	14 7/16 Inches
Power Cord Length	26 Inches
Amps	12.08 Amps
Phase	1 Phase
Voltage	120 Volts
Wattage	1450 Watts
Application	All-Purpose
Capacity	22 qt.

### Features

- Includes heavy-duty high-domed lid to accommodate large products
- Durable stainless steel construction includes large 22 qt. capacity; can cook a 28 lb. turkey
- Adjustable temperature from 150-450 degrees Fahrenheit
- Removable rack with handles for easy lift out; cool-touch carry handles
- Double-coated enamel steel pan ideal for roasting protein, baking vegetables, and keeping food warm

### Certifications



5-15P



ETL, US & Canada

## Technical Data

Color	Silver
Control Type	Thermostatic
Cover Type	Dome
Installation Type	Countertop
Material	Stainless Steel
Maximum Temperature	450 Degrees F
Number of Compartments	1 Compartment
Number of Pans	1 Pan
Plug Type	NEMA 5-15P
Power Type	Electric
Style	Roasters
Temperature Control	Adjustable
Temperature Range	150 - 450 Degrees F
Temperature Settings	Adjustable
Type	Warmers

## Plan View

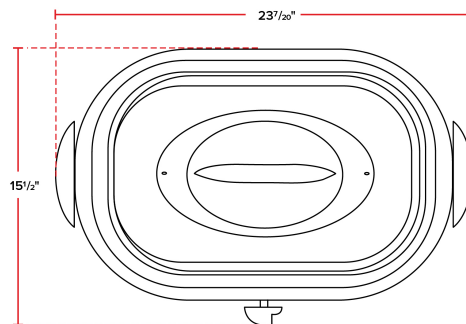
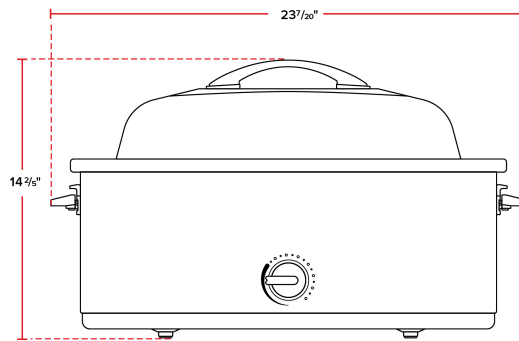



## Notes & Details

Cook, warm, roast, and bake a variety of foods with the Avantco ACR22SS 22 Qt. countertop roaster oven / warmer! This roaster oven / warmer is a great choice for roasting chickens, warming pot roast, and keeping foods hot and ready to serve. It has a large 22 qt. capacity so that it can hold foods as large as a 28 lb. turkey. With its simple controls and multi-functional design, this roaster / warmer is ideal for churches, catering services, and community organizations.

This multi-purpose oven is adjustable between 150 and 450 degrees Fahrenheit to keep food at safe holding temperatures. The wide temperature range includes features for defrosting frozen product and keeping product warm after its done cooking. This unit boasts a sleek stainless steel construction that not only helps ensure long-lasting durability, but also combines with a removable, double-coated enamel steel pan to provide you with a quick and simple end of day cleaning. The heavy-duty high-dome lid traps in heat and moisture, while the rack features handles that allow you to easily lift large, heavy product out of your roaster. The unit's cool-touch handles provide even more safety and ease of use and even doubles as a convenient cord wrap. With non-skid plastic feet, you'll never have to worry about the unit sliding around the countertop. This unit requires a 120V electrical connection for operation.

**⚠ WARNING:** This product can expose you to chemicals including lead, which are known to the State of California to cause cancer, birth defects, or other reproductive harm. For more information, go to [www.p65warnings.ca.gov](http://www.p65warnings.ca.gov).