



CBE Series Chef Base

MODEL #178CBE72HC

CABINET CONSTRUCTION

Sturdy and corrosion-resistant design features both a 430 type stainless steel exterior and interior.

Foamed-in-place CFC- and HCFC-free polyurethane insulation enhances the structural integrity of the cabinet and promotes energy efficiency.

1¾" thick stainless steel top surface features raised marine edges to help contain spills and leaks. Accommodates up to 1100 lb. of weight.

REFRIGERATION SYSTEM

Environmentally safe R290 refrigerant. Rear-mounted condensing unit positioned for easy maintenance.

DRAWERS

4 refrigerated drawers can each accommodate 2 full size, 4" deep food pans.

MODEL FEATURES

Digital temperature controller makes operation simple.

Auto defrost feature for intuitive cleaning and maintenance.

Outfitted with (4) 4" casters for mobility prior to cleaning and servicing tasks.

PROJECT: _____

MODEL: _____ SERIAL#: _____

ITEM #: _____ QUANTITY: _____

APPROVAL: _____ DATE: _____

CBE SERIES - CHEF BASE

A practical storage and productivity solution for busy kitchens.

SPECIAL FEATURES

- 1¾" thick stainless steel top with marine edges to contain spills
- Top accommodates up to 1100 lb. of weight
- 4 refrigerated drawers for food storage
- Digital temperature controls hold at 33-40°F
- Temperature display for easy monitoring
- Foamed-in-place polyurethane insulation
- Environmentally-friendly R290 refrigerant
- 430 type stainless steel interior and exterior
- Auto defrost feature
- ½ hp compressor



WARRANTY

RESIDENTIAL: Avantco assumes no liability for parts or labor coverage for component failure, factory defect or any other damages for units installed in non-commercial foodservice or residential applications.



Parts & Labor



Compressor



★ Conforms to UL & NSF-7 Standards

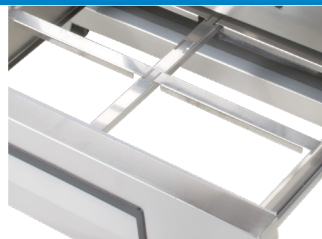

TECHNICAL DATA

Dimensions

Exterior Dimensions	72 ³ / ₈ "W x 32 ¹ / ₈ "D x 25 ⁷ / ₈ "H
Interior Dimensions	60 ⁵ / ₈ "W x 27 ¹ / ₂ "D x 16 ¹ / ₂ "H
Number of Drawers	4
4" Deep Pan Capacity (Per Drawer)	(2) Full
Top Thickness	1 ³ / ₄ "
Net Volume	16 cu. ft.
Net Weight	275 lb.
Gross Weight	321 lb.
Packing Dimensions	75"W x 35"D x 28 ¹ / ₂ "H

Cooling

Temperature Range	33°F - 40°F
Refrigerant	R290
Max. Ambient Temperature	100°F
Defrosting	Automatic
Temperature Display	Yes
Temperature Controller	Digital
Horsepower	1/5

Construction

Exterior Material	Type 430 Stainless Steel
Top Material	Type 430 Stainless Steel
Insulation Material	Foamed-in-place Polyurethane
Top Edge	Marine
Weight Capacity	1100 lb.

Electrical

Voltage	115
Amps	4.7
Hz	60
Phase	1
Plug Type	NEMA 5-15P
Electrical Cord Length	84"

PLAN VIEW

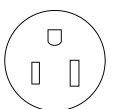
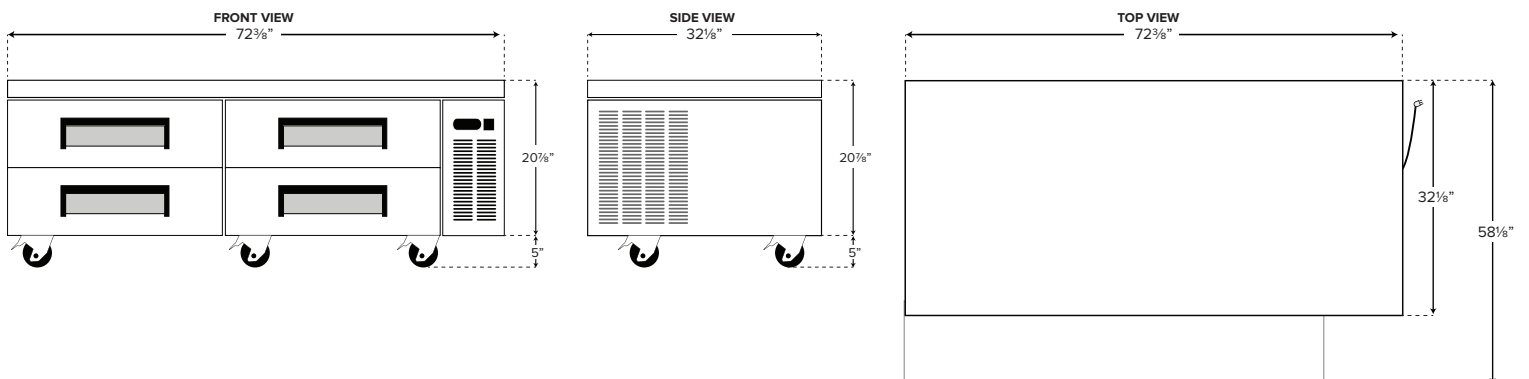

NEMA 5-15P