



**GAS**

**ELEMENTS SERIES CONVECTION OVEN**

**IMPERIAL**



## ECV-1

Shown with optional casters

### FLOW SYSTEM

- This system assures even cooking throughout the entire oven.
- Standard oven depth.
- Cooked or baked products have less shrinkage, more moisture and taste better.
- Creates an air flow pattern that simultaneously heats the inner and outer surfaces of the oven cavity.
- Recirculates hot air to maximize efficiency for energy savings.
- Fast temperature recovery.
- 1-speed 1/2 hp fan motor for high production cooking and delicate baking.
- 35,000 BTU's (10 KW) total output.
- Porcelainized oven interior for easy cleaning and provides better browning.
- 10 rack positions for maximum versatility.
- 3 oven racks included.
- Independent doors
- 50/50 doors swing open to 130°

### MANUAL CONTROLS

- Temperature controls provide maximum versatility for general baking and roasting.
- 1-speed fan switch controls bake or roast

### THERMOSTATIC OVEN CONTROL

- Snap acting temperature control: 150°F to 500°F (66° C to 260° C).
- On/Off toggle switch

### EXTERIOR

- Stainless steel solid doors
- Aluminized side panel
- Welded and finished seams
- Steel legs
- Easy to clean and maintain

**IMPERIAL**

1128 Sherborn Street | Corona, CA 92879 | 800.343.7790 | imperialrange.com | imperialsales@imperialrange.com

© 2026 Imperial Commercial Cooking Equipment Imperial reserves the right to change specifications at any time without prior notice and without any obligation for past or future equipment purchases. Visit [www.imperialrange.com](http://www.imperialrange.com) for specification updates



**GAS**

**ELEMENTS SERIES CONVECTION OVEN**

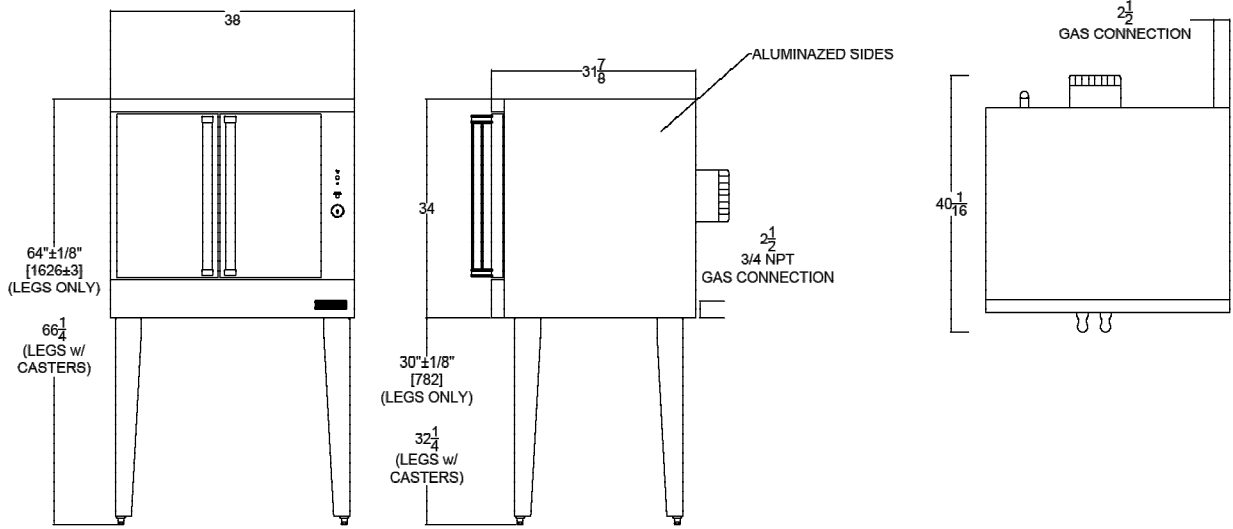

**GAS CONVECTION OVENS**

MODEL	DESCRIPTION	DIMENSIONS	CRATED DIMENSIONS	GAS OUTPUT BTU	GAS OUTPUT KW	SHIP WEIGHT KG	SHIP WEIGHT LBS
ECV-1	SINGLE DECK, STANDARD DEPTH	38" W X 40" D X 34" H (965 X 1016 X 864 MM)	39 1/2" W x 47" D X 40" H (1003 X 1194 X 1016 MM)	35000	10 KW	240	528

**UTILITY REQUIREMENTS GAS MODELS**

MODEL	VOLTAGE	PHASE	HERTZ	AMPS
ECV-1	120	1	60/50	9

**CLEARANCE REQUIREMENTS**

For use only on non-combustible floors with legs or casters; or 2 1/4" (57 mm) overhang is required when curb mounted, Provide 0" clearance from non-combustible side and rear walls, Provide 6" (152mm) minimum clearance from combustible side walls and 0" from combustible wall at rear.

One speed motor - 1/2 HP, 1725/1140 RPM



**MADE IN USA**



1128 Sherborn Street | Corona, CA 92879 | 800.343.7790 | imperialrange.com | imperialsales@imperialrange.com

© 2026 Imperial Commercial Cooking Equipment Imperial reserves the right to change specifications at any time without prior notice and without any obligation for past or future equipment purchases. Visit www.imperialrange.com for specification updates