



Enhanced Culinary Performance

Designed for culinary performance, this Chef's Edition 40-ounce container features a tamper-access lid and wider base for faster, more aggressive blending that efficiently pulls in ingredients while enhancing circulation and heat rise.

Smart Product Design

- 40-ounce capacity with NFC technology.
- CE (Chef Edition) features a tamper-access lid, making it compatible with the standard Vitamix Commercial tamper size.
- BPA-free Eastman Tritan™ container and hardened stainless-steel dual Advance® blade assembly.
- Compatible with Power-Prep™ only.



075762

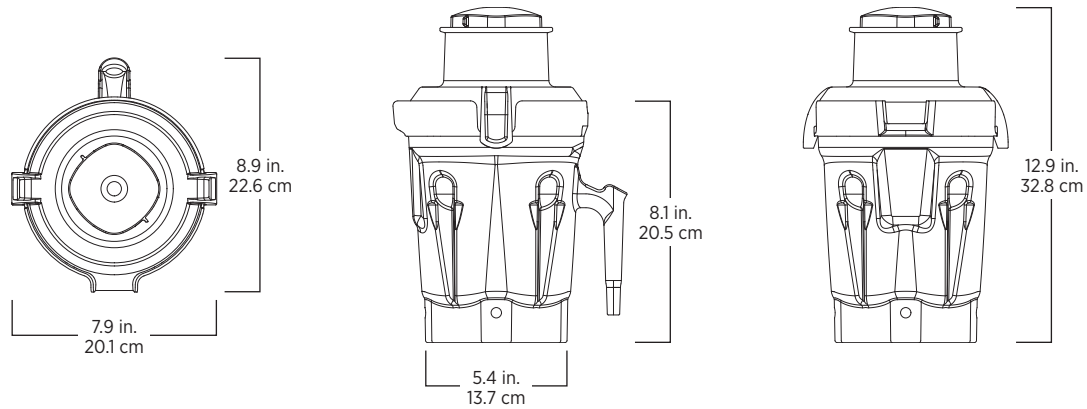

Includes 40-ounce BPA-Free, clear container with NFC, complete with blade assembly and lid.

The Accelerate Container CE is backed by a one-year or 120-hour warranty (whichever comes first) on material and workmanship. For more complete warranty terms and conditions, please visit vitamix.com/commercial.

Product Specifications

Item Number	075762
Net Weight	3.2lbs. (1.4 lbs. weight of container only)
Dimensions	12.9 x 7.9 x 8.9 in. (HxWxD)

Compatible Machines

075758 075757 075759 075760	Power-Prep™ (all configurations)
--------------------------------------	----------------------------------

Contact Information

U.S.A.

800.4DRINK4 or 800.437.4654

commercial@vitamix.com

vitamix.com/commercial

For more information, contact your local foodservice distributor.

