

Heater Proofer with Removable Universal Pan Slides

ITEM NO. _____

QUANTITY NO. _____

JOB NO. _____

SPEC NO. _____

FEATURES & BENEFITS:

- Non-Insulated - Heavy duty aluminum construction.
- Air baffle and circulating air blower provide even heat distribution.
- Proofing / Heating Module with dual elements is 120VAC, 14 amp, 60 cycle, 1440 watts. Plugs into any standard 110 outlet
- Removable chrome pan slides for variable spacing and for easy cleaning.
- Clear door for easy viewing of product while retaining heat because doors are opened less. Door gasket prevents heat loss due to a complete seal around the door. Field reversible door for right or left hinging standard. Magnetic door latch for keeping door closed during transport. Easy pull handle for opening.
- Easy to read LED thermometer.
- 25 pan slides hold a variety of pan configurations from sheet pans to steam table pans.
- Easy dual proof/heat control:
 - “Proof” mode: Humidity from 30% to 95%.
Temperatures up to 115°F (46°C)
 - “Heat” mode: Nominal Temperatures up to 180°F (82°C)
- Drip trough catches condensation to reduce wet floor conditions. Internal water pan collects condensation or is used in proofer mode.
- Corner bumpers standard to protect walls and equipment.
- 5” polyurethane plate casters standard with brakes for easy maneuverability.



NHPL-1825-UN



Controls



Magnetic Door Latch

Laboratory Certification and Approval Symbols:



141 Eileen Way • Syosset, NY 11791 • Tel: 1-800-444-3595 • Fax: 516-921-0538

www.winholt.com • sales@winholt.com

NEW YORK • PENNSYLVANIA • TEXAS • CALIFORNIA • MEXICO • CHINA

Heater Proofer with Removable Universal Pan Slides

ITEM NO. _____

JOB NO. _____

SPEC NO. _____

Heater Proofer with Removable Universal Pan Slides



SPECIFICATIONS:

CONSTRUCTION

Outside Unit constructed of .063 sheet aluminum with brushed finish. Internal frame is constructed of .125 aluminum. Frame has pre drilled holes to make door field reversible. Unit is non-insulated. Perforated air ducts in the back for air flow over product.

DOOR

Door frame is made of aluminum extrusion. Clear window is made from polycarbonate. Door has full gasket to seal in heat.

HANDLE / LATCH

One Piece door handle with magnetic latch for easy opening.

PAN SLIDES

Removable nickel chrome plate wire pan slides.

CASTERS

5 1/4" Polyurethane plate casters.

HEATER PROOFER MODULE / OPERATING RANGE

Dual heating element, 1440 Watt, 120VAC, 14 amps, 60 cycle. Unit plugs into standard 110 outlet. "Proof" mode: Humidity from 30% to 95%. Temperatures up to 115°F (46°C) "Heat" mode: Nominal Temperatures up to 180°F (82°C)

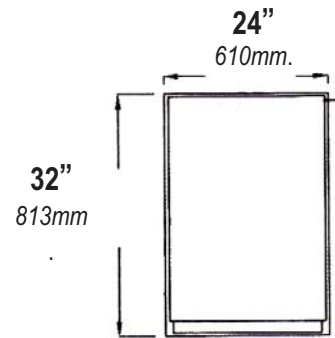

Top View

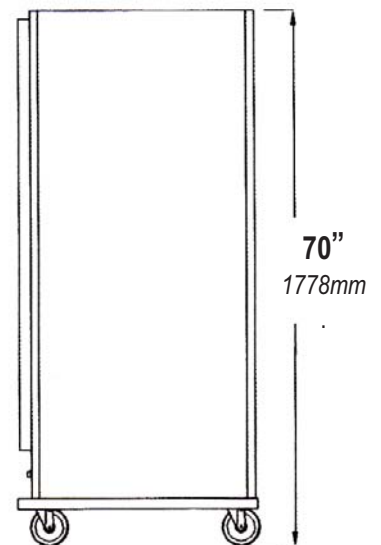

Side View

Model Number	Ordering Number	Feature	Overall Dimensions						Approx. Ship Weight	
			Width		Length		Height		(lb)	(kg)
			(in)	(mm)	(in)	(mm)	(in)	(mm)		
NHPL-1825-UN	6040067	Clear	24	610	32	813	70	1,778	235	106
Replacement Caster Information										
738A	128784	Swivel Plate Caster with 5" Polyurethane Wheel							—	
738ABK	204185	Swivel Plate Caster with 5" Polyurethane Wheel & Brake							—	
7112	122180	5" Polyurethane Wheel							—	

Win-Holt Equipment is a leading manufacturer of material & food handling equipment. Since 1946, retailers and restaurant chains have trusted Win-Holt's equipment to ensure increased productivity and efficiency in their operation. Multiple locations reduce logistics and transportation costs. All Win-Holt associates are dedicated to customer satisfaction.

For general sales and engineering information only. All units are subject to change without notice. Please consult factory for certified specifications.

141 Eileen Way • Syosset, NY 11791 • Tel: 1-800-444-3595 • Fax: 516-921-0538

www.winholt.com • sales@winholt.com

NEW YORK • PENNSYLVANIA • TEXAS • CALIFORNIA • MEXICO • CHINA