



Over 90 Years Of Quality Foodservice Products And Service



Job _____ Item No. _____

SS10 Series 11-Quart Heavy Duty, Top-Mount, Round Drop-In Food-Warmers



Model SS10TDU

DESCRIPTION

Wells heavy-duty, top-mount, drop-in, round food warmers are designed to hold heated foods at safe and fresh serving temperatures. Wells SS10 Series accommodates standard 11-quart round inset pans, and are designed for wet or dry operation.

SPECIFICATIONS

Construction – One-piece stainless steel top flange and heavy-gauge, deep-drawn stainless steel warming pans are standard features on all models. Wellslocks are standard for quick and easy installation.

Insulation - Choose between models that are fully insulated around the sides and bottom or standard non-insulated models. Fully Insulated models save energy and may be installed in non-metal counters.

Controls & Heating- Models with thermostatic or infinite controls are available. High-limits prevent overheating. Temperature-ready indicator lights are standard on all control types. Powerful tubular heating elements are located under the warming pans for quick and efficient heating and for even heat distribution.

ADDITIONAL FEATURES AVAILABLE

- 120V or 208/240V
- Drains
- Cord & plugs
- Fully insulated models or standard models
- Infinite or thermostatic controls

STANDARD FEATURES

- Accommodates standard 11-quart Insets
- 26 Models to choose from
- One-piece stainless steel top flange and heavy-gauge, deep-drawn stainless steel warming pans.
- Suitable for wet or dry operation
- Energy-Saving fully-insulated models or standard non-insulated models
- Fully Insulated models are perfect for non-metal counters (with adapter kit)
- Thermostatic or Infinite Controls
- High limits prevent overheating
- Infinite controls provided with guard ring to prevent accidental temperature change
- Thermostatic controls are recessed in a one-piece, drawn, front-mounted panel
- Wellslock standard for ease of installation
- Powerful tubular heating elements
- ½" drains available
- Cords & Plugs available
- 2-Year Limited Parts & 1-Year Limited Labor Warranty

OPTIONS & ACCESSORIES

- Inset with lid
- 8 oz. soup ladle
- Drain value extension kit
- Adaptor top for 4-quart inset
- Adaptor top for 7-quart inset
- Non-metal counter adapter kit
- Optional 72" control wiring

CERTIFICATIONS



PLEASE NOTE: SOME MODEL NUMBERS HAVE CHANGED

Sheet No. SS10-08/12



Wells Bloomfield • 10 Sunnen Dr. St. Louis, MO 63143 U.S.A.

Phone : (314) 678-6314 • Fax (314) 781-5445

www.wellsbloomfield.com © 2012 Wells Bloomfield • Printed in the U.S.A.

NOTE: Specifications are subject to change without notice and are not intended for installation purposes. See installation instructions prior to installing the unit.



Over 90 Years Of Quality Foodservice Products And Service

SS10 Series 11-Quart Heavy Duty, Top-Mount, Round Drop-In Food-Warmers

Minimum Clearances	BACK INCHES (MM)	SIDE INCHES (MM)	BOTTOM INCHES (MM)	FRONT INCHES (MM)
Standard Models	1 (25)	1 (25)	8-1/2 (216)	4* (102)
Fully Insulated Models	1 (25)	1 (25)	8 (203)	4 (102)

* When control box is located below the warmer, front clearance may be reduced to 2" or 52mm

NOTE: Specifications are subject to change without notice. Please refer to installation instructions for cut-out dimensions and fabrication details.

PLEASE NOTE: SOME MODEL NUMBERS HAVE CHANGED

SPECIFICATIONS

OLD Model Number	NEW Model Number	Description/Controls	Insulation	Installed Weight	Shipping Weight	Voltage	Watts	Phase	Cord & Plug	Plug	Drain	Approvals
SS10-120	SS10-120	Infinite	Non-Insulated	6 lbs. 2.8 kg	7 lbs. 3.2 kg	120V	450	1Ø	No	N/A	No	cRUUS cULUS NSF
SS10	SS10	Infinite	Non-Insulated	6 lbs. 2.8 kg	7 lbs. 3.2 kg	208V/240	338/450	1Ø	No	N/A	No	cRUUS cULUS NSF
SS10D-120	SS10D-120	Infinite	Non-Insulated	6 lbs. 2.8 kg	7 lbs. 3.2 kg	120V	450	1Ø	No	N/A	Yes	cRUUS cULUS NSF
SS10D	SS10D	Infinite	Non-Insulated	6 lbs. 2.8 kg	7 lbs. 3.2 kg	208V/240	620/825	1Ø	No	N/A	Yes	cRUUS cULUS NSF
SS10T-120	SS10T-120	Thermostatic	Non-Insulated	6 lbs. 2.8 kg	7 lbs. 3.2 kg	120V	825	1Ø	No	N/A	No	cRUUS cULUS NSF
SS10T	SS10T	Thermostatic	Non-Insulated	6 lbs. 2.8 kg	7 lbs. 3.2 kg	208V/240	620/825	1Ø	No	N/A	No	cRUUS cULUS NSF
SS10T-230	SS10T-230	Thermostatic	Non-Insulated	6 lbs. 2.8 kg	7 lbs. 3.2 kg	230V	825	1Ø	No	N/A	No	CE
SS10TD-120	SS10TD-120	Thermostatic	Non-Insulated	6 lbs. 2.8 kg	7 lbs. 3.2 kg	120V	825	1Ø	No	N/A	Yes	cRUUS cULUS NSF
SS10TD	SS10TD	Thermostatic	Non-Insulated	6 lbs. 2.8 kg	7 lbs. 3.2 kg	208V/240	620/825	1Ø	No	N/A	Yes	cRUUS cULUS NSF
SS10TD-230	SS10TD-230	Thermostatic	Non-Insulated	6 lbs. 2.8 kg	7 lbs. 3.2 kg	230V	825	1Ø	No	N/A	Yes	CE
SS10ULT-120	SS10TU-120	Thermostatic	Non-Insulated	6 lbs. 2.8 kg	7 lbs. 3.2 kg	120V	825	1Ø	No	N/A	No	UL cULUS NSF
SS10ULT	SS10TU	Thermostatic	Non-Insulated	6 lbs. 2.8 kg	7 lbs. 3.2 kg	208V/240	620/825	1Ø	No	N/A	No	UL cULUS NSF
SS10ULTD-120	SS10TDU-120	Thermostatic	Non-Insulated	6 lbs. 2.8 kg	7 lbs. 3.2 kg	120V	825	1Ø	No	N/A	Yes	UL cULUS NSF
SS10ULTD	SS10TDU	Thermostatic	Non-Insulated	6 lbs. 2.8 kg	7 lbs. 3.2 kg	208V/240	620/825	1Ø	No	N/A	Yes	UL cULUS NSF
SS10TUC-120	SS10TUC-120	Thermostatic	Non-Insulated	6 lbs. 2.8 kg	7 lbs. 3.2 kg	120V	825	1Ø	Yes	NEMA 5-15P	No	UL cULUS NSF
SS10TUC	SS10TUC	Thermostatic	Non-Insulated	6 lbs. 2.8 kg	7 lbs. 3.2 kg	208V/240	620/825	1Ø	Yes	NEMA 6-15P	No	UL cULUS NSF
SS10TDUC-120	SS10TDUC-120	Thermostatic	Non-Insulated	6 lbs. 2.8 kg	7 lbs. 3.2 kg	120V	825	1Ø	Yes	NEMA 5-15P	Yes	UL cULUS NSF
SS10TDUC	SS10TDUC	Thermostatic	Non-Insulated	6 lbs. 2.8 kg	7 lbs. 3.2 kg	208V/240	620/825	1Ø	Yes	NEMA 6-15P	Yes	UL cULUS NSF
SS10TUI-120	SS10TUI-120	Thermostatic	Fully Insulated	11.4 lbs. (5.2) kg	12.4 lbs. (5.6) kg	120V	825	1Ø	No	N/A	No	UL cULUS NSF
SS10TUI	SS10TUI	Thermostatic	Fully Insulated	11.4 lbs. (5.2) kg	12.4 lbs. (5.6) kg	208V/240	620/825	1Ø	No	N/A	No	UL cULUS NSF
SS10TDUI-120	SS10TDUI-120	Thermostatic	Fully Insulated	11.4 lbs. (5.2) kg	12.4 lbs. (5.6) kg	120V	825	1Ø	No	N/A	Yes	UL cULUS NSF
SS10TDUI	SS10TDUI	Thermostatic	Fully Insulated	11.4 lbs. (5.2) kg	12.4 lbs. (5.6) kg	208V/240	620/825	1Ø	No	N/A	Yes	UL cULUS NSF
SS10TUCI-120	SS10TUCI-120	Thermostatic	Fully Insulated	11.4 lbs. (5.2) kg	12.4 lbs. (5.6) kg	120V	825	1Ø	Yes	NEMA 5-15P	No	UL cULUS NSF
SS10TUCI	SS10TUCI	Thermostatic	Fully Insulated	11.4 lbs. (5.2) kg	12.4 lbs. (5.6) kg	208V/240	620/825	1Ø	Yes	NEMA 6-15P	No	UL cULUS NSF
SS10TDUCI-120	SS10TDUCI-120	Thermostatic	Fully Insulated	11.4 lbs. (5.2) kg	12.4 lbs. (5.6) kg	120V	825	1Ø	Yes	NEMA 5-15P	Yes	UL cULUS NSF
SS10TDUCI	SS10TDUCI	Thermostatic	Fully Insulated	11.4 lbs. (5.2) kg	12.4 lbs. (5.6) kg	208V/240	620/825	1Ø	Yes	NEMA 6-15P	Yes	UL cULUS NSF

Due to periodic changes in designs, methods, procedures, policies and regulations, the specifications contained in this sheet are subject to change without notice. While Wells exercises good faith efforts to provide information that is accurate, we are not responsible for errors or omissions in information provided or conclusions reached as a result of using the specifications. By using the information provided, the user assumes all risks in connection with such use.



Wells Bloomfield • 10 Sunnen Dr. St. Louis, MO 63143 U.S.A.
Phone : (314) 678-6314 • Fax (314) 781-5445
www.wellsbloomfield.com © 2012 Wells Bloomfield • Printed in the U.S.A.

NOTE: Specifications are subject to change without notice and are not intended for installation purposes. See installation instructions prior to installing the unit.



Over 90 Years Of Quality Foodservice
Products And Service

SS-10 Series 11-Quart Heavy Duty, Top-Mount, Round Drop-In Food-Warmers

INCHES
MM

NOTE: Specifications are subject to change without notice. Please refer to installation instructions for cut-out dimensions and fabrication details.

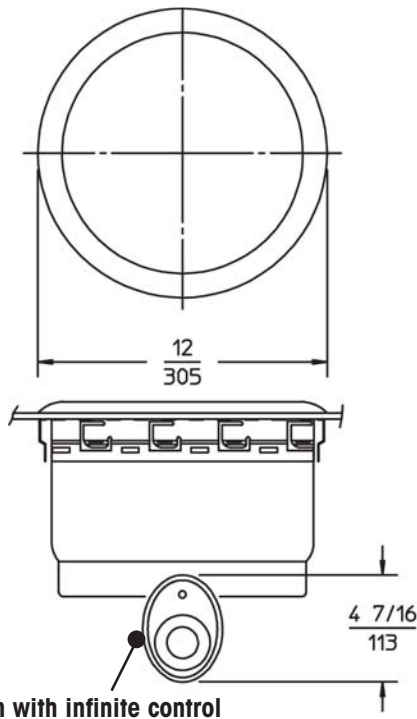

NOTE: * CONTROL MUST NOT BE MOUNTED IN THIS HIGH TEMPERATURE AREA.

**PRODUCT DIMENSIONS
STANDARD MODELS ONLY**

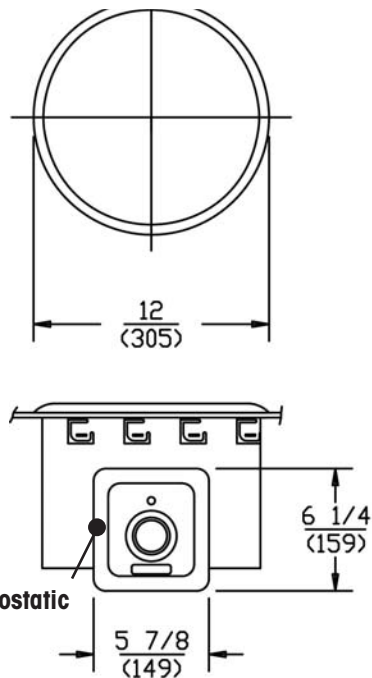
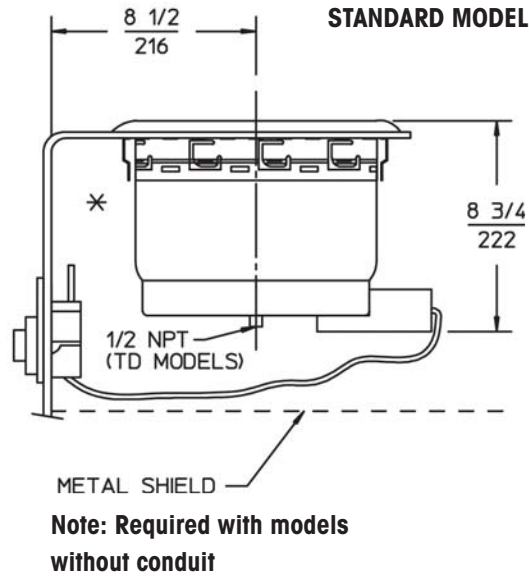

**PRODUCT DIMENSIONS
INSULATED MODELS ONLY**

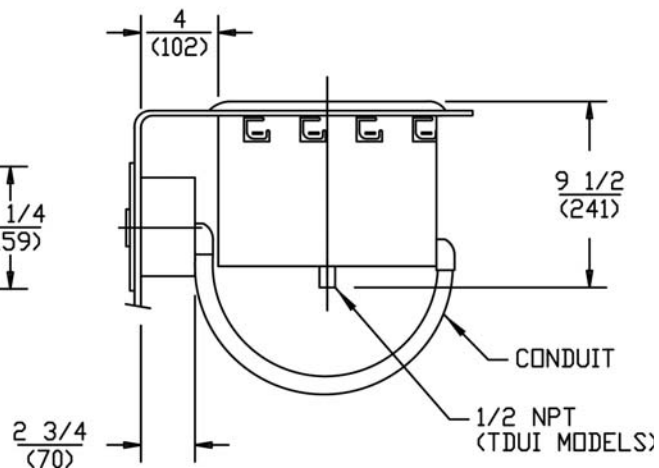

Due to periodic changes in designs, methods, procedures, policies and regulations, the specifications contained in this sheet are subject to change without notice. While Wells exercises good faith efforts to provide information that is accurate, we are not responsible for errors or omissions in information provided or conclusions reached as a result of using the specifications. By using the information provided, the user assumes all risks in connection with such use.



Wells Bloomfield • 10 Sunnen Dr. St. Louis, MO 63143 U.S.A.
Phone : (314) 678-6314 • Fax (314) 781-5445
www.wellsbloomfield.com © 2012 Wells Bloomfield • Printed in the U.S.A.

NOTE: Specifications are subject to change without notice and are not intended for installation purposes. See installation instructions prior to installing the unit.