



WIC50

Commercial Ice Crusher



PREP

Commercial Ice Crusher



MAIN FEATURES

- High-output performance crushes up to 600 lb. of ice per hour
- Adjustable ice sizes at the flip of a switch
- Choose small or large sized crushed ice for any application
- 5 lb. capacity ice cube hopper
- 10.5 lb. removable ice bucket
- Efficient and easy-to-use countertop design
- Powerful heavy-duty commercial motor
- Durable commercial grade stainless steel housing and self-feeding blades
- Built-in interlock protection for enhanced safety
Ice hopper lid must be closed and bucket in place to activate blades
- White LED ready indicator lights the ice bucket when the unit is ready for loading.
- Removable drip grate
- Cord wrap on back of unit for tidy storage and convenience
- Crushes bagged or cubed ice
- Great for beverages, raw seafood bars, store frozen display cases, concession stands, catering and more
- Limited 1-year warranty

ELECTRICAL

Voltage: 120

Frequency: 60Hz

Watts: 110

Amps: 0.9

Plug Type: NEMA 5-15P

Cord Length: 6 feet

SALES FEATURES

Efficient and easy to use, this heavy-duty yet portable countertop ice crusher produces up to 600 lb. of crushed ice per hour in both small and large sizes. Designed for quick setup with simple plug-and-play operation. Ideal for bars, supermarket frozen food cases, and iced seafood buffets, this commercial kitchen essential features a powerful motor and stainless steel blades to ensure a steady supply of ice. Durably built for years of high-output use, in a compact, space-saving countertop design.



@waringproducts

©2026 Waring

314 Ella T. Grasso Avenue, Torrington, CT 06790

Tel. 800-492-7464 • Fax 860-496-9008

waring.com

WIC50



Commercial Ice Crusher WIC50

DIMENSIONS

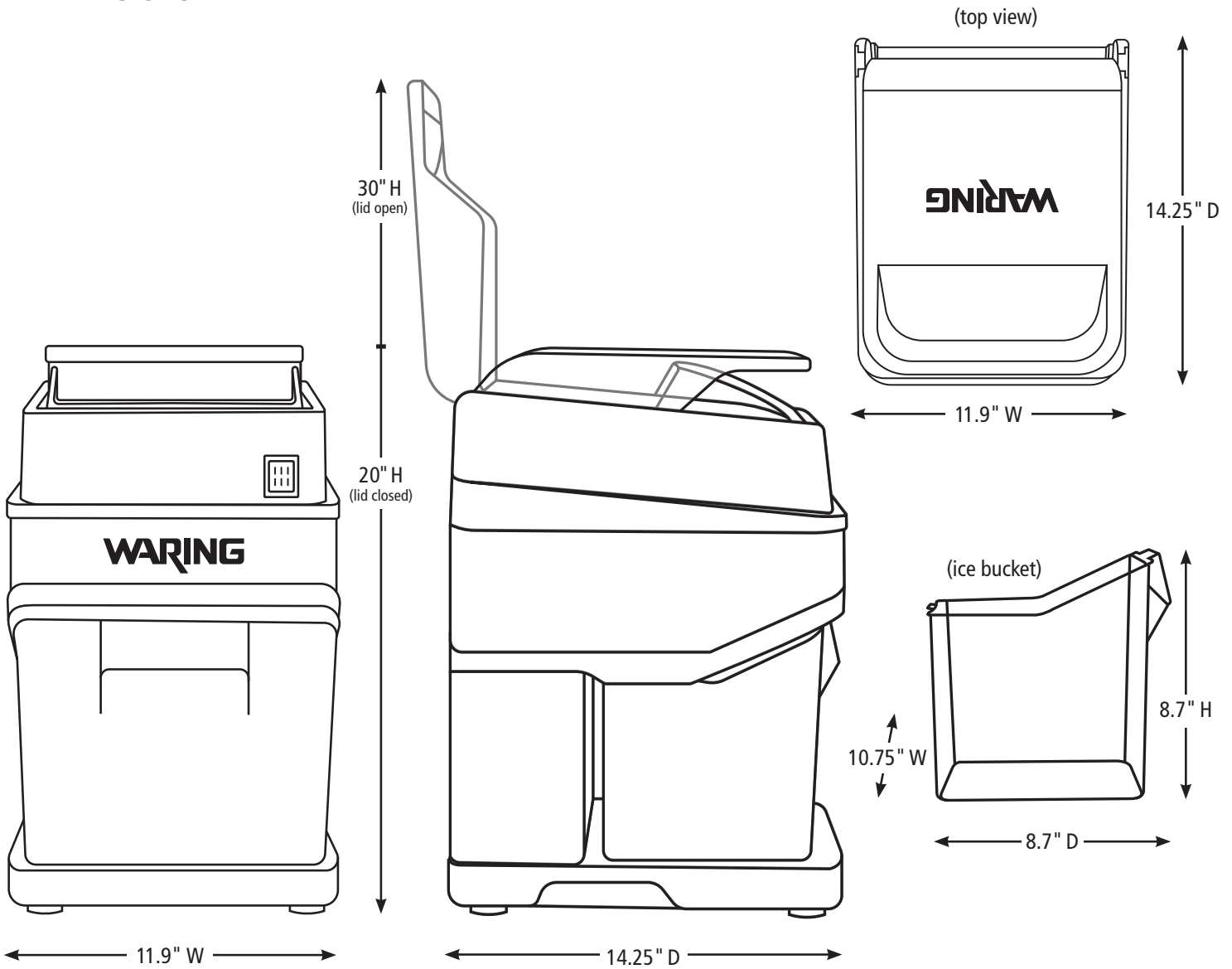

Out of Box Weight: 23.2 lb.

ORDERING INFORMATION	#STD. PKG.	GIFTBOX WEIGHT	CUBIC FEET	BOX DIMENSIONS D X W X H	UPC	CASE PKG.	MC WEIGHT	MC DIMENSIONS D X W X H	MBC
WIC50 – Commercial Ice Crusher	1	28 lb.	3.532	14" x 18.75" x 23.25"	040072108457	1	30 lb.	19.25" x 14.5" x 24"	10040072108454



@waringproducts

©2026 Waring
314 Ella T. Grasso Avenue, Torrington, CT 06790
Tel. 800-492-7464 • Fax 860-496-9008

waring.com

26WC96188/ REV 02/26