

PALLADIO 330 EVO TOP 13"

Heavy-duty Deli / Supermarket slicer

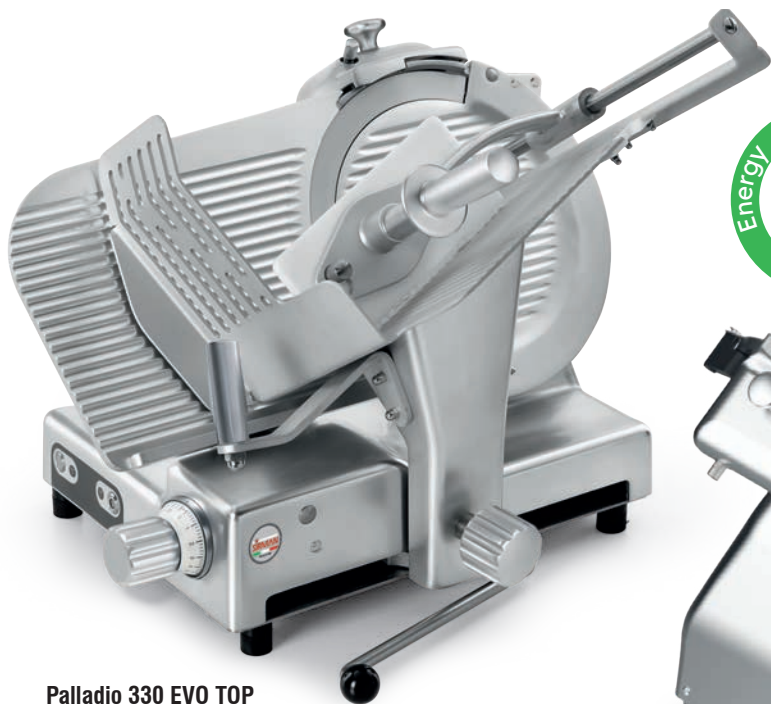

Palladio 330 EVO TOP



Palladio 330 EVO TOP
with scale

The ultimate **EVOLution** from SIRMAN
13" high-quality, heavy-duty slicer designed for high-volume retail
applications, setting the highest standards in the industry for:

Dependability, Yield and Profitability

- One-piece sanitary polished and anodized aluminum construction
- Widest cutting capacity in a compact footprint
- Low-profile, ergonomic design with an extremely smooth carriage motion
- ½ Hp heavy-duty motor for continuous service and higher torque for cheese slicing
- Stainless steel controls, IP67 dustproof and waterproof rating
- Dual stage cam system allows precise, thin and thick slicing
- Complete stainless steel drive shaft assembly
- Built-in sharpener for perfect results and safety - unlike remote devices
- Waterproof from above

Optional

- 19705020 Vegetable Chute
- 19510453P Fence, rectangular/round products

Operation:	Gravity feed.
Construction:	Polished, anodized aluminum alloy.
Knife:	One piece, chromium plated 100Cr6 forged carbon steel blade.
Sharpener:	Built-in, removable, two stone dual action.

Hygiene and Safety

- Rounded, edgeless design
- Increased gap between blade and machine body
- One-piece carriage with seamless, see-through hand guard
- Improved blade guard removal system
- Zero blade exposure to prevent injuries when cleaning
- Tilt-carriage with zero blade exposure
- Permanent blade rim guard covering the non-slicing portion of the blade edge
- Lift lever to easily and safely clean under the slicer (factory installed option)
- Overload protection
- No volt release
- Certified to the new NSF ANSI 8 2010 standard

Slice thickness:	0-1" (0-24 mm), infinitely variable
Motor:	0.55 Hp (410 W), fan cooled.
Electrical:	120V AC, 60Hz, 2A (220V, 50Hz available on request).
Plug & Cord:	Attached, flexible, 3 wire SJTO AWG 18, 6'4" long. NEMA 5-15 P
Controls:	ON/OFF stainless steel keypad, IP 67 waterproof protection. No voltage release.

UL US LISTED
 Certified to UL Standard 763
 and NSF Standard 08
 Certified to CSA Standard C22.2

ETL
 INTERTEK
 SANITATION LISTED



Improved blade guard removal system



Completely sealed stainless steel shaft



Increased gap between blade and machine body



One-piece carriage with seamless, see-through hand guard

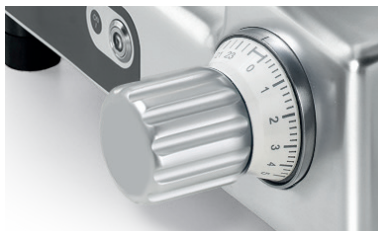

Dual stage cam system allows precise, thin and thick slicing

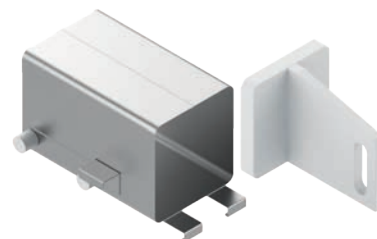

Food Tube 2.0 option

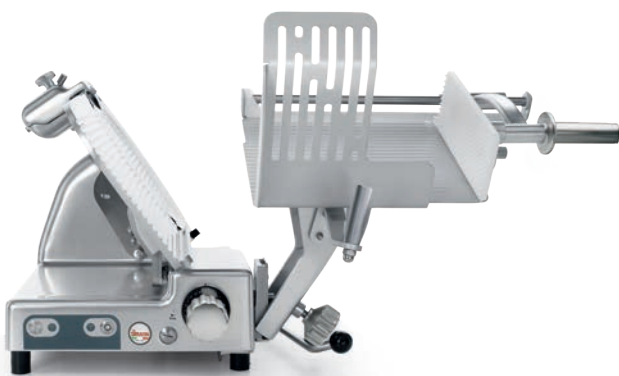

Tilt-carriage with zero blade exposure



Lift lever

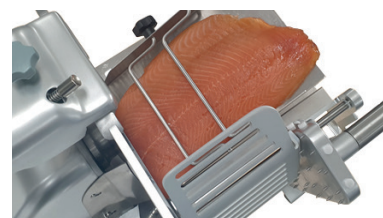

Poseidon-Fish tray optional



Blade Removal Tool (BRT) option

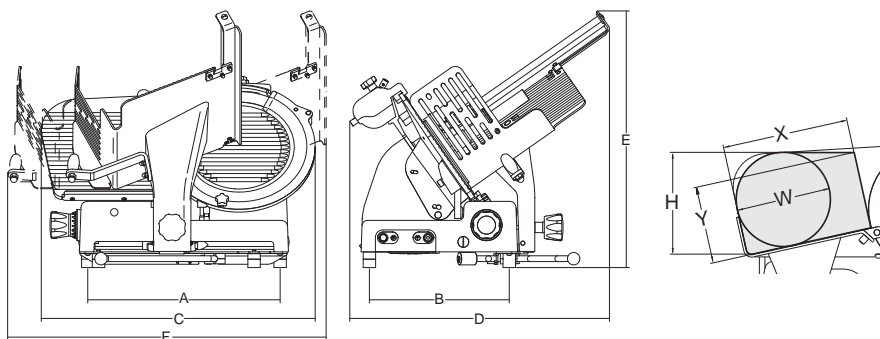

	Ø Blade	Motor	Cut thickness	Blade rpm	Carriage stroke	Hopper	A	B	C	D	E	F	X	Y	H	W	Net weight	Shipping	Gross weight
	mm/inch	watt/Hp	inch.	rpm	inch.	inch.	inch.	inch.	inch.	inch.	inch.	inch.	inch.	inch.	inch.	inch.	lbs.	inch.	lbs.
Palladio 330 EVO TOP	330/13"	410-0.55	1"	216	12 ² / ₁₆ "	12" x 10 ¹ / ₄ "	18 ⁵ / ₁₆ "	13 ³ / ₈ "	25 ³ / ₁₆ "	24 ³ / ₁₆ "	24 ¹³ / ₃₂ "	28 ¹⁵ / ₁₆ "	10 ¹ / ₂ "	7 ¹ / ₂ "	10 ⁵ / ₈ "	9 ¹ / ₄ "	95	33" x 34" x 33"	145