

Product Specifications

Combination Convertible Service Above Refrigerated Self-Service Case

Lengths include end panels

- HOU3852R-E3 40"L x 42"D x 53"H
- HOU4852R-E3 50"L x 42"D x 53"H
- HOU5652R-E3 58"L x 42"D x 53"H
- HOU7452R-E3 76"L x 42"D x 53"H



MODEL SHOWN: HOU4852R-E3

STANDARD FEATURES

- Breeze™ w/EnergyWise s/c refrigeration
- 3' models do not include center divider in upper display
- Clear glass shelf, lighted (T-8) in upper display
- Condensate pan (self-contained refrig. only)
- Convertible baffle in upper display
- Curved double pane, lift-up front glass w/o lock
- Cutaway end panels w/mirror interior in lower section
- Flat front panel
- Integrated average product temperature of 40°F or less
- Lower refrigerated self-service display deck
- One year parts & labor; 5 year compressor warranty
- Shelving removable and adjustable on 1" centers
- T-8 top & shelf lights

Features	Standard	Options
EXTERIOR COLOR	<input type="checkbox"/> Black	
INTERIOR COLOR	<input type="checkbox"/> Black	
REAR EXTERIOR COLOR	<input type="checkbox"/> Painted - White	
TRIM COLOR	<input type="checkbox"/> Black	
BASE	<input type="checkbox"/> Levelers	
UPPER REAR	<input type="checkbox"/> Clear glass rear sliding doors w/o lock	
ELECTRICAL CONNECT	<input type="checkbox"/> 6' straight blade power cord (self-cont.)	
REFRIGERATION	<input type="checkbox"/> Breeze™ w/EnergyWise s/c refrigeration	
MISCELLANEOUS		<input type="checkbox"/> Second year parts & labor warranty (excludes compressor)

Product Specifications

Intended Environment: Type I - Designed to operate in ambient conditions of 75°F with 55% relative humidity unless noted otherwise in system information below.	
Zone	Intended Product To Be Displayed
All	Packaged / unpackaged refrigerated products
Integrated Prod Temp ° F	
40	

PLAN VIEW

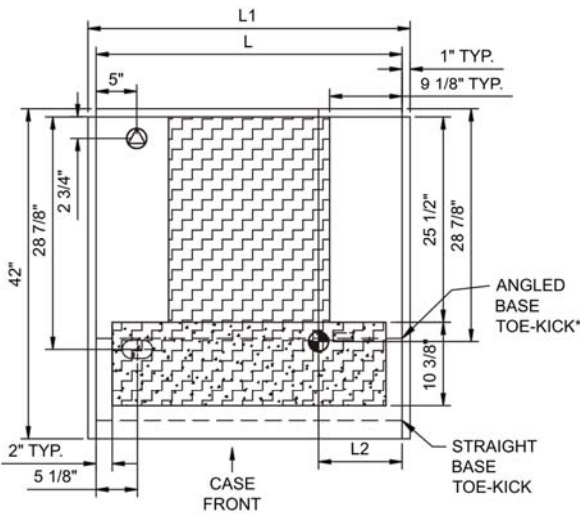

SIDE VIEW

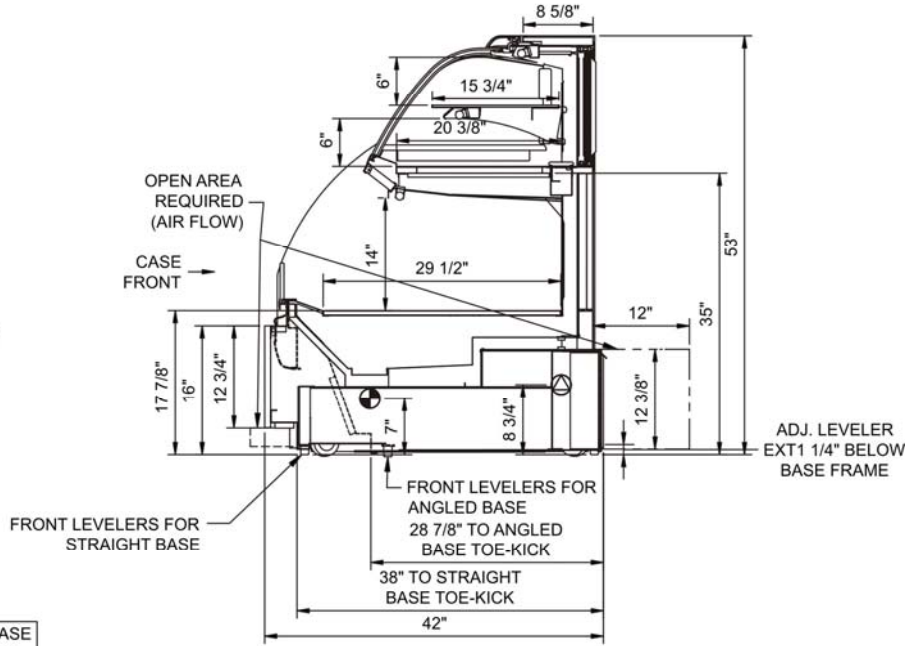

*FOR ANGLD BASE CASES, SERVICE ACCESS AREAS END AT TOE-KICK

NOTE: ALL DIMENSIONS APPROXIMATE

- ELECTRICAL JUNCTION BOX (SUPPLIED WITH 6" LEADS OR POWER CORD).
- LOCATION OF DRAIN TUBE FOR REMOTE REF. ONLY (SUPPLIED WITH 1/2" OR 1 1/2" PVC TUBE).

- REFRIGERATION LINE CONNECTION.
- REMOTE FLOOR SINK & UTILITIES ACCESS AREA.

- SELF-CONTAINED CASE SERVICE ACCESS AREA.
- DRY CASE SERVICE ACCESS AREA.

Model Technical Specifications

Model	L"	L1"	L2"	System	Circuit Volts	Phs	Freq	Amps ***	Watts	Wires	NEMA Plug	SST	BTUH	Ship Wt
HOU3852R-E3	N/A	40.00	4.75	Self-Contained	Circuit #1 110-120	1	60	12.00	1,307	2+G	5-15P or L5-15P	N/A	N/A	950
HOU4852R-E3	N/A	50.00	4.75	Self-Contained	Circuit #1 110-120	1	60	16.00	1,519	2+G	5-20P or L5-20P	N/A	N/A	1,050
HOU5652R-E3	N/A	58.00	5.75	Self-Contained	Circuit #1 120/230V	1	60	10.92	1,764	3+G	14-20P or L14-20P	N/A	N/A	1,100
HOU7452R-E3	N/A	76.00	5.75	Self-Contained	Circuit #1 120/230V	1	60	12.00	2,134	3+G	14-20P or L14-20P	N/A	N/A	1,220

*** Does not include electric defrost on freezer models.

Important Notes:

- 1) ELECTRICAL NOTE: If GFCI is required, a GFCI breaker MUST be used in lieu of a GFCI receptacle
- 2) 43" Minimum door entry clearance required (without shipping skid).
- 3) Compressor air intake from rear and out front panel at toe kick. Toe kick cannot be blocked.
- 4) Units are supplied with levelers. They must be adjusted during installation to ensure that unit is level and plumb. Dimensions reflect levelers extended 1 1/4".

Regulatory Approvals:	
All Models	Accordance with AHRI Std 1200 ETL Listed to UL 471 ETL Listed to CAN/CSA 22.2 No. 120 ETL Sanitation to NSF 7



In Accordance with
AHRI Std 1200

DOE 2012
Energy Efficiency
Compliant