



RESTAURANT SERIES RANGES SERIES: BP-72"



Bakers Pride® 72" ranges feature two 40,000 BTUH ovens. Choose from a variety of stovetop configurations: a twelve-burner range or a combination of burners with a 12", 24", 36", 48", or 60" griddle.

Cleaning is easy thanks to the lift-off burner heads and removeable oven doors. The cast-iron section grates are designed to allow pots to slide from section to section and are engineered with an anti-clogging shield for long-lasting performance. In the oven, a unique burner baffle distributes heat evenly throughout the oven, which is also porcelainized on five contact surfaces.

For even more control within the cooking chamber, choose the optional convection oven. Simply turn the motor off to use it as a standard oven.

Available for use with natural gas or liquid propane.

FEATURES AT A GLANCE

- 40,000 BTUH burners
- Lift-off burner heads
- Natural or LP gas
- Two 30" (762 mm) wide, 40,000 BTUH ovens
- 1" (25 mm) thick griddle (on specific models)
- Burner for every 12" (305 mm) of griddle surface
- Rack guides have four positions for two standard wire racks (Ribbed bottom is fifth position.)
- 7" (178 mm) landing ledge
- 6" (152 mm) adjustable legs
- Oven is porcelainized on bottom, sides, back, and door liner
- Unique burner baffle design
- Removable oven doors
- Stainless steel front, sides, landing ledge, back guard, and shelf
- 12" (305 mm) sq. cast-iron section grates
- Anti-clogging grate shield
- One-year limited warranty

OPTIONS & ACCESSORIES

- Convection ovens
- Left-hand griddle (Right is standard.)
- Raised griddle
- Additional oven racks
- Quick disconnect and flexible gas hose
- Casters (set of six)
- Gas conversion kits
- Thermostatic griddle
- Stub back

VANTAGE STOVETOP CONFIGURATION

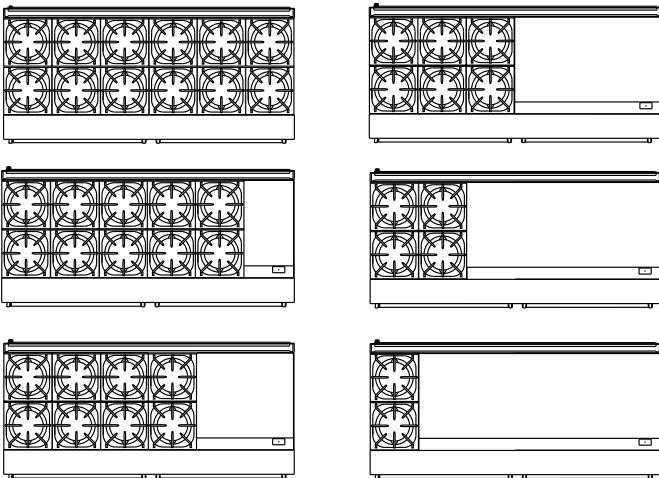

EQUIPMENT DIMENSIONS

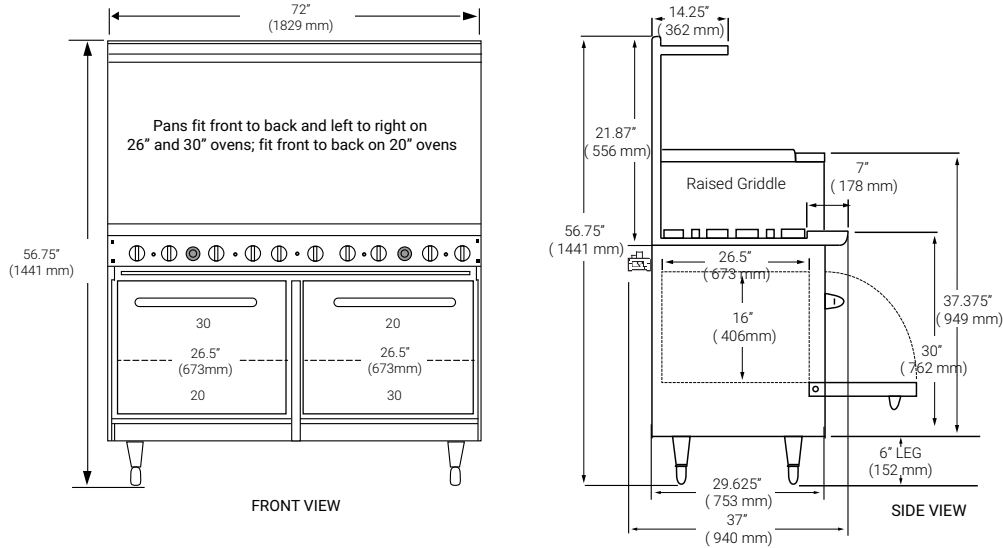

MECHANICAL SPECIFICATIONS

Model #	BTU	# 12" sq. Grates	Griddle Width	Oven Width	Overall Dim (W x H x D)*	Carton Dim (W x H x D)	Cubic Feet	Cubic Meter	Ship Wt.
72-BP-12B-S30	560,000	12	n/a	30" (762)	72" x 56.75" x 37" (1829 x 1441 x 940)				1,150 (522kg)
72-BP-10B-G12-S30	500,000	10	12" (305)	30" (762)	72" x 56.75" x 37" (1829 x 1441 x 940)				1,200 (544kg)
72-BP-8B-G24-S30	440,000	8	24" (610)	30" (762)	72" x 56.75" x 37" (1829 x 1441 x 940)				1,220 (553kg)
72-BP-6B-G36-S30	380,000	6	36" (914)	30" (762)	72" x 56.75" x 37" (1829 x 1441 x 940)				1,165 (528kg)
72-BP-4B-G48-S30	320,000	4	48" (1219)	30" (762)	72" x 56.75" x 37" (1829 x 1441 x 940)				1,350 (612kg)
72-BP-2B-G60-S30	260,000	2	60" (1524)	30" (762)	72" x 56.75" x 37" (1829 x 1441 x 940)				1,425 (646kg)

*Height includes 6" legs. Depth includes 4" gas regulator.

OVEN INTERIOR DIMENSIONS

30" x 15" x 26.5"
(762 x 381 x 673)

REQUIRED CLEARANCES

Combustible

Left	10" (254 mm)
Right	10" (254 mm)
Back	4" (102 mm)

GAS CONNECTIONS

Manifold pressure is 5.0" W.C. or natural gas 10.0" for propane gas. Manifold size is 3/4" NPT.
3/4" pressure regulator supplied with equipment to be installed at time of connection.
Must specify type of gas and elevation if over 2000 ft. when ordering.



Freight Class: 110
FOB: Allen, 75013

Bakers Pride reserves the right to modify specifications or discontinue models without incurring obligation. Dimensions nominal.

Bakers Pride Oven Company, LLC is a wholly owned subsidiary of Standex International Corporation.