

TECH SPECS

All 4000-CB models have 32" diameter one piece reflector

SERIES 4000-CB PORTABLE

MODEL NO.	BTU/Hr	GAS	IGNITION	FINISH	DIMENSION H x W	WHEELS	CYLINDER	WEIGHT IN LBS.
4005-CB	38,000	LP	BATTERY ELECTRIC	STAINLESS STEEL	89 3/4" x 32 1/4"	YES	30 OR 20 lb. cyl.	37
4002-CB	38,000	LP	BATTERY ELECTRIC	BLACK	89 3/4" x 32 1/4"	YES	30 OR 20 lb. cyl.	37

SERIES 4000-CB POST MOUNT

MODEL NO.	BTU/Hr	GAS	IGNITION	FINISH	DIMENSION HEIGHT x WIDTH	GAS PRESURE		GAS INLET	MOUNTING	WEIGHT IN LBS.
						MANI-FOLD	MAX. INLET			
4SN5-CB	38,000	NAT	BATTERY ELECTRIC	STAINLESS STEEL	88 1/5" x 32"	5" W.C.	14" W.C.	1/2"	FLOOR/DECK	50
4SL5-CB	38,000	LP	BATTERY ELECTRIC	STAINLESS STEEL	88 1/5" x 32"	10" W.C.	14" W.C.	1/2"	FLOOR/DECK	50
4BN6-CB	38,000	NAT	BATTERY ELECTRIC	BLACK	88 1/5" x 32"	5" W.C.	14" W.C.	1/2"	FLOOR/DECK	50
4BL6-CB	38,000	LP	BATTERY ELECTRIC	BLACK	88 1/5" x 32"	10" W.C.	14" W.C.	1/2"	FLOOR/DECK	50

MINIMUM CLEARANCES TO COMBUSTIBLES:

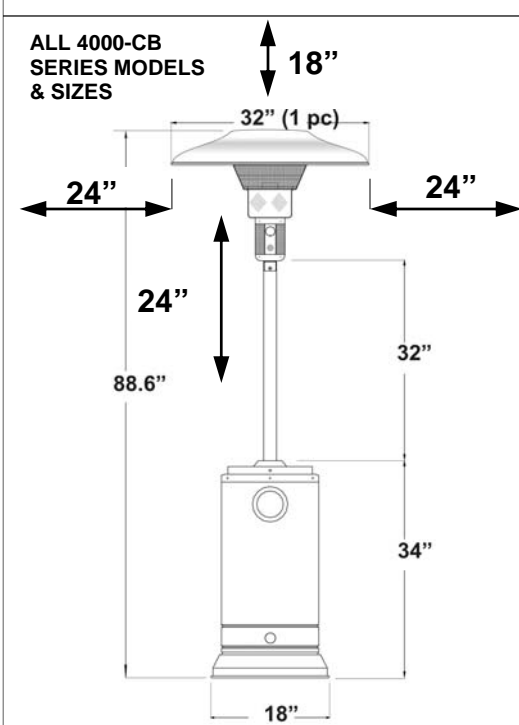

MODELS

PORTABLE: 4002-CB
4005-CB



FIXED MOUNT: 4BN/L6-CB
4SN/L5-CB



4002/5-CB SHIPPING: DISPLAY CARTON = 18" x 18" x 35" + REFLECTOR CARTON
4N/L5/6 POST SERIES SHIPS IN THREE CARTONS: BURNER & BASE, POST, REFLECTOR