

3M™ Water Filtration Products

SPEC# _____

QUANTITY _____

application:

ESPRESSO

models:

ESP114-T & ESP124-T

The 3M™ Water Filtration Products ESP114-T and ESP124-T single-cartridge systems help provide consistent high quality water for espresso and espresso-based drinks at flow rates up to 0.5 gpm (1.9 lpm). A strong-acid sodium ion-exchange resin reduces calcium and magnesium ions to help prevent hard scale formation on the heating coils and boilers resulting in energy inefficiency, downtime, and expensive service calls. Premium activated carbon reduces chlorine taste and odor and bitterness associated with poor water quality.

- MODEL ESP114-T removes hardness up to 700 grains.
- MODEL ESP124-T removes hardness up to 1,100 grains.

PRODUCT BENEFITS

- Consistent, great tasting espresso and espresso drinks from water with reduced hardness and chlorine taste and odor.
- Reduced hard scale formation on the heating coils by the reduction of calcium and magnesium ions results in improved energy efficiency and reduced downtime and expensive service calls.
- Valve-in-head design simultaneously shuts off and vents water with 1/4 turn, allowing for simple and virtually trouble-free cartridge change-outs.
- 3/8" FNPT horizontal inlet and outlet ports allow direct or easily adaptable connections to existing plumbing lines.
- Optional pressure gauge allows monitoring of downstream water pressure.
- Sanitary Quick Change (SQC) encapsulated cartridges reduce contamination during change-outs.
- FDA CFR-21 and/or NSF compliant materials.



ESP114-T

ESP124-T

PRODUCT SPECIFICATIONS

Model Number	Part Number	Reduction Claims	Capacity	Service Flow Rate	Replacement Cartridge	Sizing
ESP114-T	56176-09	Hardness, Chlorine Taste & Odor	700 Grains	0.5 gpm (1.9 lpm)	PS114: 56109-09	Approximate Capacity in Gallons = Grain Capacity/Incoming Water Hardness in Grains
ESP124-T	56176-10		1,100 Grains		PS124: 56109-07	



ESP114-T & ESP124-T

3M™ Water Filtration Products

SPEC# _____
QUANTITY _____
MODEL NUMBER _____
PART NUMBER _____

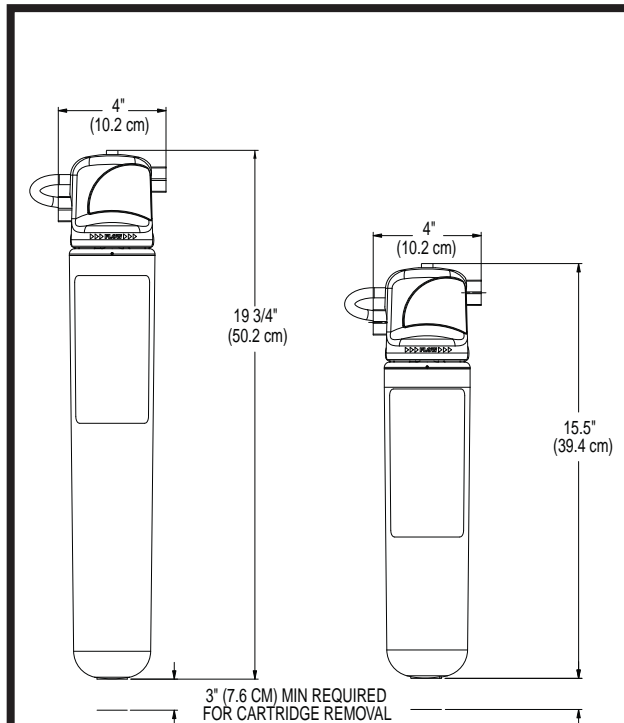

⚠ WARNING: To reduce the risk associated with the ingestion of contaminants:

- Do not use with water that is microbiologically unsafe or of unknown quality without adequate disinfection before or after the system.

CUNO Incorporated recommends regularly scheduled maintenance and replacement of the filter cartridge(s) in order for the product to perform as advertised/sold. CUNO shall not be liable for system failures due to improper maintenance.

LIMITED WARRANTY

CUNO Incorporated warrants this Product (excluding disposable filter cartridge(s)) to be free from defects in material and workmanship for five (5) years from the date of purchase. The disposable filter cartridge is warranted from defects in material and workmanship for a period of one (1) year from the date of purchase. This warranty does not cover failures resulting from abuse, misuse, alteration or damage not caused by CUNO or failure to follow installation and use instructions. If the Product is defective CUNO will replace the Product or refund your Product purchase price. CUNO will not be liable for any indirect, special, incidental, or consequential damages arising from the use of this Product. Some states do not allow the exclusion or limitation of incidental or consequential damages, so the above limitation may not apply to you. To obtain warranty service, mail your request to Warranty Claims, CUNO Incorporated, 400 Research Parkway, Meriden, CT 06450. Proof of purchase (original sales receipt) must accompany the warranty claim, along with a complete description of the Product, model number and alleged defect. This warranty gives you specific legal rights and you may have other rights which vary from state to state, or country to country.

PHYSICAL SPECIFICATIONS

- System includes a head assembly, integral mounting bracket, and single cartridge filter.
- Optional downstream pressure gauge port in top of head assembly.
- Inlet and outlet plumbing connections are 3/8" FNPT.
- System incorporates an internal automatic 1/4 turn shut-off valve.
- Filter cartridges are o-ring seal type.
- System maximum operating pressure of 125 psi (862 kPa) and operating temperatures of 100°F (37.8°C).
- Recommended service flow rate is 0.5 gpm (1.9 lpm).
- Filter cartridges incorporate premium activated carbon media and strong-acid ion-exchange media in the sodium form.
- System materials are FDA CFR-21 and/or NSF compliant.
- Cartridge body is constructed from high-impact polypropylene.
- Cartridges are sanitary in design, requiring no contact with the filter media during cartridge change-out.
- Filter cartridges requires no pre-activation.
- Shipping weight: ESP114-T — 20 lbs. (9.1 kg) per case
ESP124-T — 12 lbs. (5.44 kg) per case
- Case Quantity: ESP114-T — 6
ESP124-T — 4

IMPORTANT: INSTALLATION TIPS

These installation tips are for informational purposes only and are not intended to be used as actual installation instructions. CAUTION: To reduce the risk associated with property damage due to water leakage:

- **Read and follow** Use Instructions before installation and use of this system.
- Installation and use **MUST** comply with all state and local plumbing codes.
- **Protect from freezing**, remove filter cartridge when temperatures are expected to drop below 40°F (4.4°C).
- **Do not install on hot water supply lines.** The maximum operating water temperature of this filter system is 100°F (37.8°C).
- **Do not install** if water pressure exceeds 125 psi (862 kPa). If your water pressure exceeds 80 psi (552 kPa), you must install a pressure limiting valve. Contact a plumbing professional if you are uncertain how to check your water pressure.
- **Do not install** where water hammer conditions may occur. If water hammer conditions exist you must install a water hammer arrester. Contact a plumbing professional if you are uncertain how to check for this condition.
- The disposable filter cartridge **MUST** be replaced every 12 months, at the rated capacity or if a noticeable reduction in flow rate occurs.

