

SPEC# _____

QUANTITY _____

application: **MULTIPLE EQUIPMENT**

models:

DP190/DP195



3M™ Water Filtration Products Models DP190 & DP195 dual port water filtration systems help provide consistent high quality water for the multiple applications of cold beverages, ice and coffee at a combined flow rate of up to 5 gpm (18.9 lpm). Two separate streams exit the manifold. Both streams have reduced sediment and chlorine taste and odor. One stream has added scale inhibition media from a dedicated cartridge to help reduce the ability of calcium and magnesium to precipitate as hard scale on the evaporator plates of an ice machine and/or the heating coils of a coffee brewer. The second stream supplies cold beverage dispensers and includes no added scale inhibitor.

The DP190 filters combine chlorine taste and odor reduction with cyst, bacteria and sediment reduction to 0.2 micron. **The DP195 filters** combine chlorine taste and odor reduction with sediment reduction to 3 micron for more turbid water.

PRODUCT BENEFITS

- One system with dual outlet connections simultaneously supplies cold beverage dispensers and ice machines/coffee brewers.
- Up to 5 gpm (18.9 lpm) total flow of water especially treated for consistent great tasting cold beverages, clearer and consistent ice and the perfect cup of coffee or tea.
- Revolutionary **Integrated Membrane Pre-Activated Carbon Technology (“IMPACT”)** dual-zone media cartridge construction combines a membrane in series with premium activated carbon to provide superior throughput and cartridge life.
- Reduction of up to 99.99% of common water-borne heterotrophic bacteria by membrane filtration as tested by CUNO (HF90 replacement cartridge).
- NSF and/or FDA CFR-21 compliant materials.
- Built-in bacteria inhibitor intended to reduce fouling of media (HF90 replacement cartridge).
- Reduction of scale build-up on evaporator plates and heating coils from a controlled forced-feed orifice addition of scale inhibitor, as tested by CUNO.
- Sanitary Quick Change (SQC) encapsulated cartridge design allows for fast and easy cartridge change-outs with a 1/4 turn.
- 3/4” NPT horizontal inlet and outlet ports allow direct or easily adaptable connections to existing plumbing lines.
- Expansion kit available to serve higher capacities and flow rates.
- Manifold includes outlet check valves.

PRODUCT SPECIFICATIONS

Model Number	Part Number	Reduction Claims	Nominal Micron Rating	Capacity	Service Flow Rate	Application	Replacement Cartridge	Sizing
DP190	56243-01	Cysts ¹ , Bacteria ² , Sediment, Chlorine Taste and Odor, Scale	0.2	54,000 gallons (204,412 liters)	5.0 gpm (18.9 lpm)	Most Normal Water	DP190 CARTRIDGE 56138-01 (HF90 & HF8-S)	For simultaneous operation of carbonators, coffee machines and ice machines
DP195	56243-02	Sediment, Chlorine Taste and Odor, Scale	3			Higher Turbidity Water	DP195 CARTRIDGE 56138-04 (HF95 & HF8-S)	

¹Includes oocysts of cryptosporidium and toxoplasma and cysts of giardia and entamoeba
²As tested with E.Coli ATCC (11229)

DP190/DP195

3M™ Water Filtration Products

SPEC# _____
QUANTITY _____
MODEL NUMBER _____
PART NUMBER _____

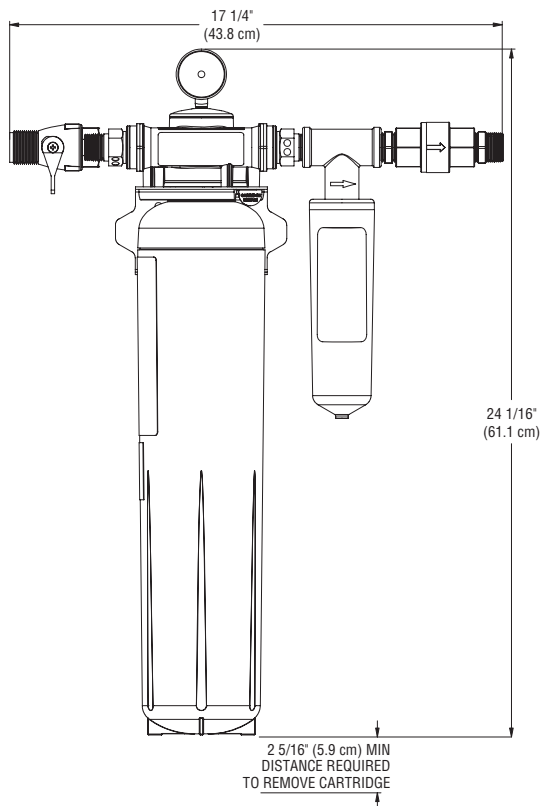

⚠ WARNING: To reduce the risk associated with the ingestion of contaminants:

- Do not use with water that is microbiologically unsafe or of unknown quality without adequate disinfection before or after the system. Systems certified for cyst reduction may be used on disinfected water that may contain filterable cysts. EPA Establishment #070595-CT-001

CUNO Incorporated recommends regularly scheduled maintenance and replacement of the filter cartridge(s) in order for the product to perform as advertised/sold. CUNO shall not be liable for system failures due to improper maintenance.

LIMITED WARRANTY

Seller warrants its equipment, with the exception of the disposable filter cartridges, against defects in workmanship and material for a period of five (5) years from date of shipment from the factory under normal use and service and otherwise when such equipment is used in accordance with instructions furnished by Seller and for purposes disclosed in writing at the time of purchase, if any. The disposable filter cartridge is warranted from defects in material and workmanship for a period of one (1) year from the date of purchase. Any unauthorized alteration or modification of the equipment by Buyer will void this warranty. Seller's liability under this warranty shall be limited to the replacement or repair, F.O.B. point of manufacture, of any defective equipment or part which, having been returned to the factory, transportation charges prepaid, has been inspected and determined by the Seller to be defective. THIS WARRANTY IS IN LIEU OF ANY OTHER WARRANTY, EITHER EXPRESSED OR IMPLIED, AS TO DESCRIPTION, QUALITY, MERCHANTABILITY, FITNESS FOR ANY PARTICULAR PURPOSE OR USE, OR ANY OTHER MATTER. Under no circumstances shall Seller be liable to Buyer or any third party for any loss of profits or other direct or indirect costs, expenses, losses or consequential damages arising out of or as a result of any defects in or failure of its products or any part or parts thereof or arising out of or as a result of parts or components incorporated in Seller's equipment but not supplied by the Seller.

PHYSICAL SPECIFICATIONS

- System includes a single cartridge manifold with built-in pressure gauge, inlet water shut-off valve, outlet check valves, mounting brackets, a single cartridge filter and a dedicated external scale inhibition cartridge.
- Inlet and outlet plumbing connections are 3/4" NPT (choice of male or female is included).
- Filter cartridge is o-ring seal type.
- System maximum operating pressure of 125 psi (862 kPa) and operating temperature of 100°F (37.8°C).
- Recommended combined service flow rate is up to 5 gpm (18.9 lpm).
- Filter cartridge incorporates a bacteriostatic carbon block filtration medium (HF90 replacement cartridge). Second cartridge includes a scale inhibition medium (HF8-S).
- System materials are NSF and/or FDA CFR-21 compliant.
- Cartridges are sanitary in design, requiring no contact with the filter media during cartridge change-out.
- Filter cartridges require no pre-activation.
- Shipping weight: 15 lbs. (6.8 kg).
- Operating weight: 16.5 lbs. (7.5 kg).

IMPORTANT: INSTALLATION TIPS

These installation tips are for informational purposes only and are not intended to be used as actual installation instructions. CAUTION: To reduce the risk associated with property damage due to water leakage:

- **Read and follow** Use Instructions before installation and use of this system.
- Installation and use **MUST** comply with all state and local plumbing codes.
- **Protect from freezing**, remove filter cartridge when temperatures are expected to drop below 40°F (4.4°C).
- **Do not install on hot water supply lines.** The maximum operating water temperature of this filter system is 100°F (37.8°C).
- **Do not install** if water pressure exceeds 125 psi (862 kPa). If your water pressure exceeds 80 psi (552 kPa), you must install a pressure limiting valve. Contact a plumbing professional if you are uncertain how to check your water pressure.
- **Do not install** where water hammer conditions may occur. If water hammer conditions exist you must install a water hammer arrester. Contact a plumbing professional if you are uncertain how to check for this condition.
- The disposable filter cartridge **MUST** be replaced every 12 months, at the rated capacity or if a noticeable reduction in flow rate occurs.

