



Profit from the Eagle Advantage®

# Specification Sheet

## Short Form Specifications

Eagle 2200 Series Modular Angle Fillers, model \_\_\_\_\_. Top, front, and backsplash to be heavy gauge type 304 stainless steel, with galvanized sides. (Front /Rear) filler available in 30°, 45°, 60°, and 90° angles. All units have predrilled mounting holes.

Eagle 2200 Series Modular Corner Drainboards, model \_\_\_\_\_. Top, front, and backsplash to be heavy gauge type 304 stainless steel with galvanized sides, and embossed work surface. #MRC-22 includes one 1 1/2" O.D. galvanized tubular leg with adjustable bullet foot. Both units have predrilled mounting holes.



front angle filler



rear angle filler



front corner drainboard



rear corner drainboard

Item No.:	_____
Project No.:	_____
S.I.S. No.:	_____

## 2200 Series Modular Angle Fillers and Corner Drainboards

### MODELS:

- |                                  |                                  |                                 |
|----------------------------------|----------------------------------|---------------------------------|
| <input type="checkbox"/> MF30-22 | <input type="checkbox"/> MF60-22 | <input type="checkbox"/> MRC-22 |
| <input type="checkbox"/> MR30-22 | <input type="checkbox"/> MR60-22 | <input type="checkbox"/> MFC-22 |
| <input type="checkbox"/> MF45-22 | <input type="checkbox"/> MF90-22 |                                 |
| <input type="checkbox"/> MR45-22 | <input type="checkbox"/> MR90-22 |                                 |

### Modular Angle Fillers

- Stainless steel front and top.
- Galvanized steel sides.
- Joins 2200 Series units by the corners.
- Front and rear fillers available in angles of 30°, 45°, 60° and 90°.
- All units have predrilled mounting holes.

### Modular Corner Drainboards

- All-welded construction.
- Galvanized panels attach to other equipment, stainless steel outer panels remain visible.
- Joins 2200 Series units by the corners.
- MRC-22 provided with one 1 1/2" (41mm)-diameter leg.
- All units have predrilled mounting holes.

**EAGLE GROUP**  
 100 Industrial Boulevard, Clayton, DE 19938-8903 USA  
 Phone: 302-653-3000 • Fax: 302-653-2065  
 www.eaglegrp.com

**Foodservice Division: Phone 800-441-8440**  
**MHC/Retail Display Divisions: Phone 800-637-5100**

For custom configuration or fabrication needs, contact our **SpecFAB® Division**.  
 Phone: 302-653-3000 • Fax: 302-653-3091 • e-mail: specfab@eaglegrp.com

## AUTOQUOTES



EG40.58 Rev. 08/11

**Spec sheets available for viewing, printing or downloading from our online literature library at [www.eaglegrp.com](http://www.eaglegrp.com)**

*Eagle Foodservice Equipment, Eagle MHC, SpecFAB®, and Retail Display are divisions of Eagle Group. ©2011 by the Eagle Group*



Item No.: \_\_\_\_\_  
 Project No.: \_\_\_\_\_  
 S.I.S. No.: \_\_\_\_\_

## 2200 Series Modular Angle Fillers

### 30° Angle Fillers

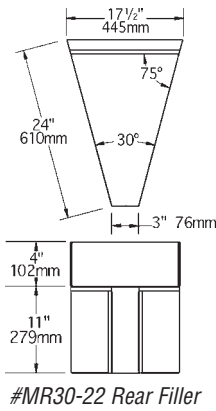
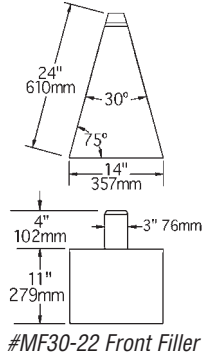

FRONT model #	REAR model #	weight lbs.	weight kg
MF30-22	MR30-22	16	7.3

### 45° Angle Fillers

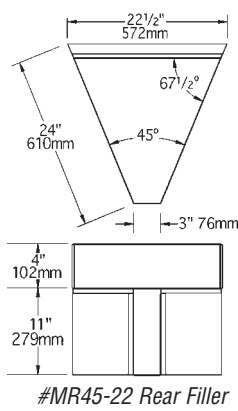
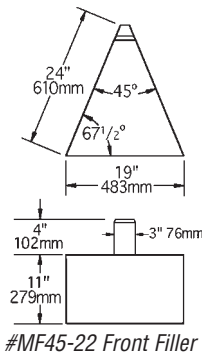

FRONT model #	REAR model #	weight lbs.	weight kg
MF45-22	MR45-22	17	7.7

### 60° Angle Fillers

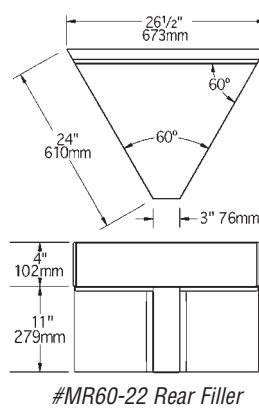
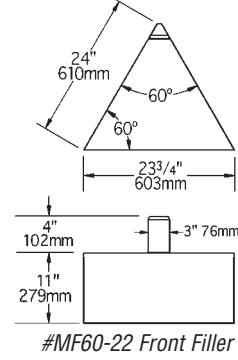

FRONT model #	REAR model #	weight lbs.	weight kg
MF60-22	MR60-22	20	9.0

### 90° Angle Fillers

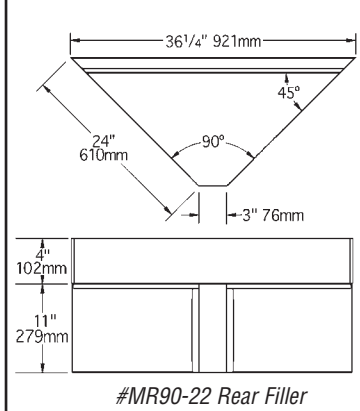
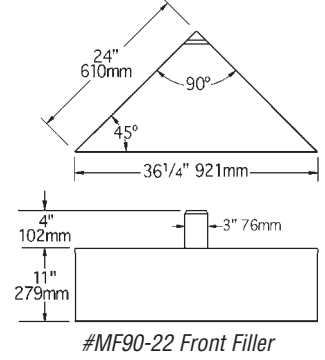

FRONT model #	REAR model #	weight lbs.	weight kg
MF90-22	MR90-22	22	10.0

## Corner Drainboards – 2200 Series

FRONT model #	REAR model #	weight lbs.	weight kg
MFC-22	MRC-22	42	19.1

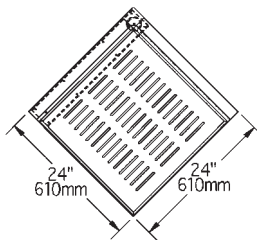

#MRC-22 Rear Corner Drainboard

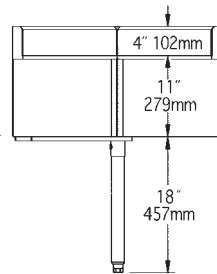

#MFC-22 Front Corner Drainboard

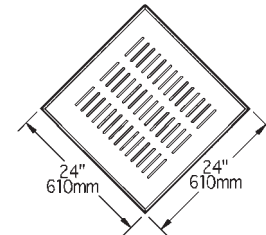

**EAGLE GROUP**  
 100 Industrial Boulevard, Clayton, DE 19938-8903 USA  
 Phone: 302-653-3000 • Fax: 302-653-2065  
 www.eaglegrp.com

Foodservice Division: Phone 800-441-8440  
 MHC/Retail Display Divisions: Phone 800-637-5100

Spec sheets available for viewing, printing or downloading from our online literature library at [www.eaglegrp.com](http://www.eaglegrp.com)

Although every attempt has been made to ensure the accuracy of the information provided, we cannot be held responsible for typographical or printing errors. Information and specifications are subject to change without notice. Please confirm at time of order.

Printed in U.S.A.  
 ©2011 by Eagle Group  
 Rev. 08/11