

# MagiKitch'n®

## Model LPAGA SERIES High Performance Outdoor Gas Grills

Project \_\_\_\_\_

Item No. \_\_\_\_\_

Quantity \_\_\_\_\_



LPAGA60 Shown with optional equipment

### APPLICATION

The LPAGA outdoor catering Models offer high production outdoor grilling. All models are mounted on heavy duty casters for easy mobility over the toughest terrain. The modular design makes the appliance transportable to any event location. Many options and accessories are available to tailor your grill to match your menu selection and operational needs at any event in various settings.

### STANDARD FEATURES & ACCESSORIES

- V-shaped stainless steel radiant for each burner
- Front removable water tubs
- Heavy Duty Top Grids(s) 30" (76 cm) & 60" (152 cm)
- 1-1/4" Burners are 20,000 Btu energy output
- Regulator hose assembly with QCC1 connection (Two (2) on 60" models)
- Heavy duty 14 Ga. steel construction
- Removable support base for easy transport
- Heavy duty 6" swivel casters
- 8" (20.3 cm) stainless steel front service shelf
- Runner tube pilot system
- Pilot runner tube protection cover prevents clogging
- Individual burner controls for precision cooking
- Stainless steel trim kit
- Tank Cart System (40 Lb. Horizontal LP Bottles)

### Model Size and Gas Btu/Hr Rate

- LPAGA30 80Kbtu
- LPAGA30SS 80Kbtu
- LPAGA60 160Kbtu
- LPAGA60SS 160Kbtu

### OPTIONS & ACCESSORIES (AT ADDITIONAL COST)

- 15" (30" Models only)  30"
- Long Life Burner (11 Ga. 304 Stainless Steel)
- Hood(s) with Thermometer
- 15" (30" Models only)  30"  60"
- Slip on Service Shelves
- Side shelf  Rear shelf
- Steamer Option
- 15" Steamer set  30" Steamer set
- Steamer Pan Set
- Half pan set  Full pan set
- MagiGriddle
- 15" (30" Models only)  30"
- Utility Handles
- Side mount (No side shelf)  Water Tub
- Additional Items:
- Top grid scraper (Heavy duty grids only)
- Water tub drain system
- Cutting Board
- Piezo ignition system (standard on all SS models)
- EZ Roll System (Large 14" wheels one end)
- Outdoor vinyl cover
- 30" & 60" Wind guard (Model Size Specific)

### APPROVALS



Model LPAGA Series High Performance Outdoor Gas Grills



MagiKitch'n • P.O. Box 501, Concord, NH 03302-0501 •  
603-225-6684 • FAX: 603-225-8497 • [www.magikitch'n.com](http://www.magikitch'n.com)

L10-567 Rev 1 05/15 Printed in the USA

## Model LPAGA Series High Performance Outdoor Gas Grills

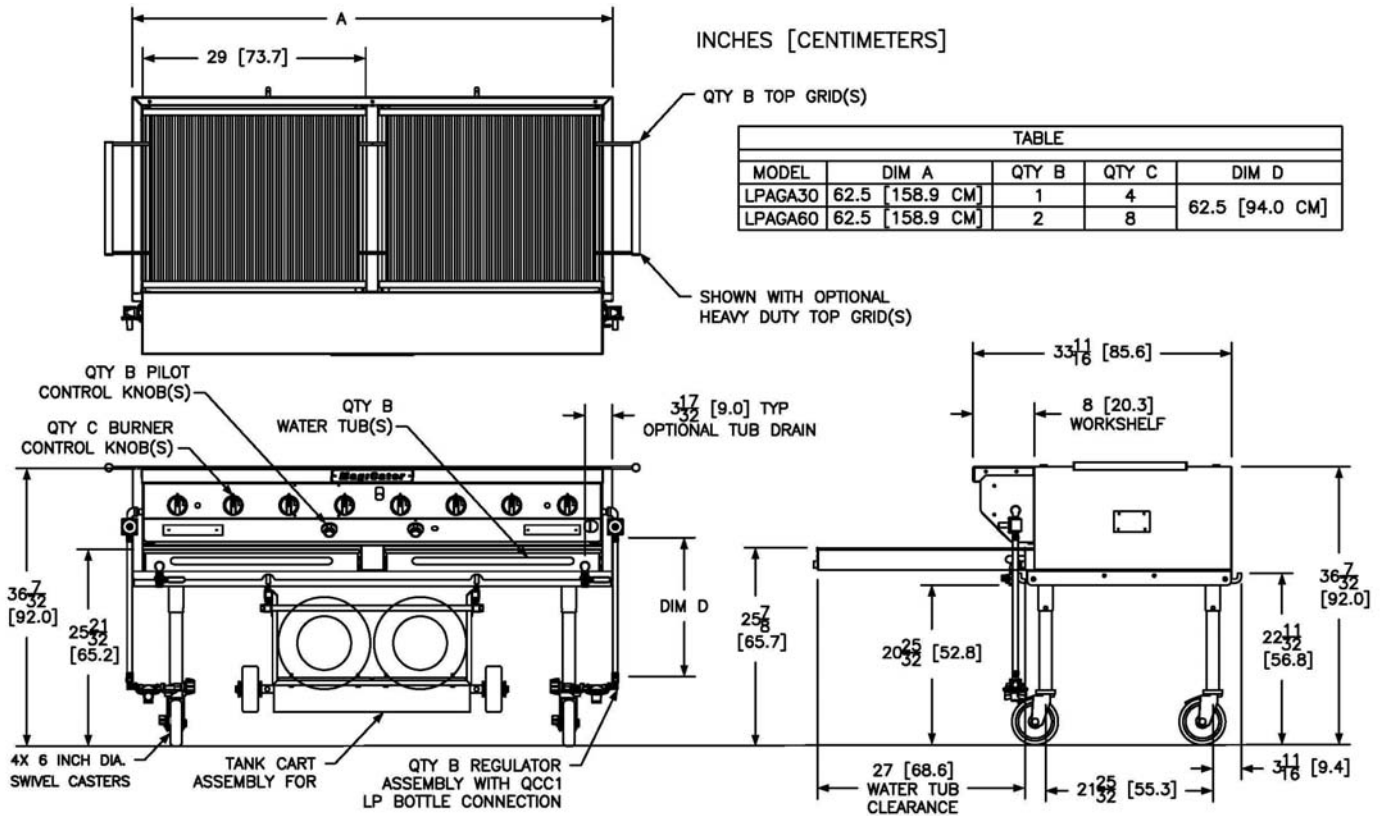

INDIVIDUAL CHARBROILER SPECIFICATIONS				
Model Size	LPAGA30	LPAGA60		
Gas BTU/HR (kW)	80,000 (23.4)	160,000 (46.8)		
Burners	4	8		
Top Grid Cooking Area	696 in <sup>2</sup> (4,483 cm <sup>2</sup> )	1392 in <sup>2</sup> (8,967cm <sup>2</sup> )		
Water Tubs	1	2		
Top Grid(s)	29 x 24" (73.5 x 61.0 cm)	(2X) 29 x 24" (73.5 x 61.0 cm)		
SHIPPING INFORMATION (Approximate)				
Model Size	LPAGA30	LPAGA60		
Shipping	215 lbs. (98 kg)	288 lbs. (131 kg)		
Shipping Crate L x W x H	41" x 35" x 36" (114cm x 89cm x 91cm)	71" x 37" x 25" (180cm x 94cm x 64cm)		
Shipping Cube	29.9 ft <sup>3</sup> (0.9 m <sup>3</sup> )	38.0 ft <sup>3</sup> (1.1 m <sup>3</sup> )		
INSTALLATION INFORMATION				
GAS PRESSURE REQUIREMENTS		GAS CONNECTION REQUIREMENTS		
	LP Gas	LPAGA30	LPAGA60	
Supply Pressure*	11 - 13" W.C (27.4 mbars/ 2.74 kPa)	One (1) LP supply assembly includes: (1) 3/8" NPT regulator (5"-12" WC) (1) 3/8" NPT LP 2 stage regulator (1) 3/8" LP rated gas hose	Two (2) LP supply assembly includes: (1) 3/8" NPT regulator (5"-12" WC) (1) 3/8" NPT LP 2 stage regulator (1) 3/8" LP rated gas hose	
Burner Pressure	10" W.C. (25 mbars / 2.4 kPa)			
<b>IMPORTANT- This appliance is intended for outdoor use ONLY.</b>				
* This appliance is intended for use with LP gas bottles in accordance with NFPA regulations.				
CLEARANCES (Can Not Be Mounted W/O Supplied Casters)				
Front min	Floor min.	Non-Combustible material		Charbroiler Combustion Area
27" (68.6 cm)	21" (53.3 cm)	Sides min. 15" (38.1 cm)	Rear min. 8" (20.3 cm)	Do not block / restrict flue gases from venting from the appliance or operate under canopies.
SHORT FORM SPECIFICATION				
Provide MagiKitch'n model LPAGAx radiant outdoor charbroiler mounted on heavy duty casters. Unit shall be gas heated and shall cook by means of gas burners. Unit shall be heavy duty 14 Ga. steel construction. Provide with independent gas burners. Individual burner controls shall be mounted every 7-1/4 inches for flexible use. Convertible design allows operator to quickly add additional accessories with out the use of tools in most instances. Provide Options and Accessories as follows:				



**MagiKitch'n** • P.O. Box 501, Concord, NH 03302-0501 •

603-225-6684 • FAX: 603-225-8497 • [www.magikitchn.com](http://www.magikitchn.com) L10-567 Rev 1 05/15 Printed in the USA

We reserve the right to change specifications without notice and without incurring any obligation for equipment previously or subsequently sold.