



ADA Compliant

This Space for Architect/Engineer Approval

Job Name _____ Date _____

Model Specified _____ Quantity _____

Customer/Wholesaler _____

Contractor _____

Architect/Engineer _____

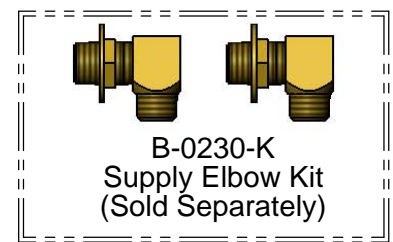
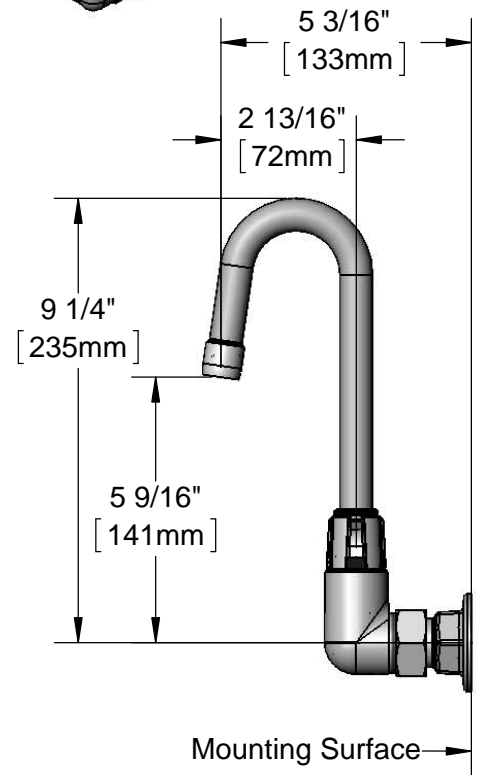
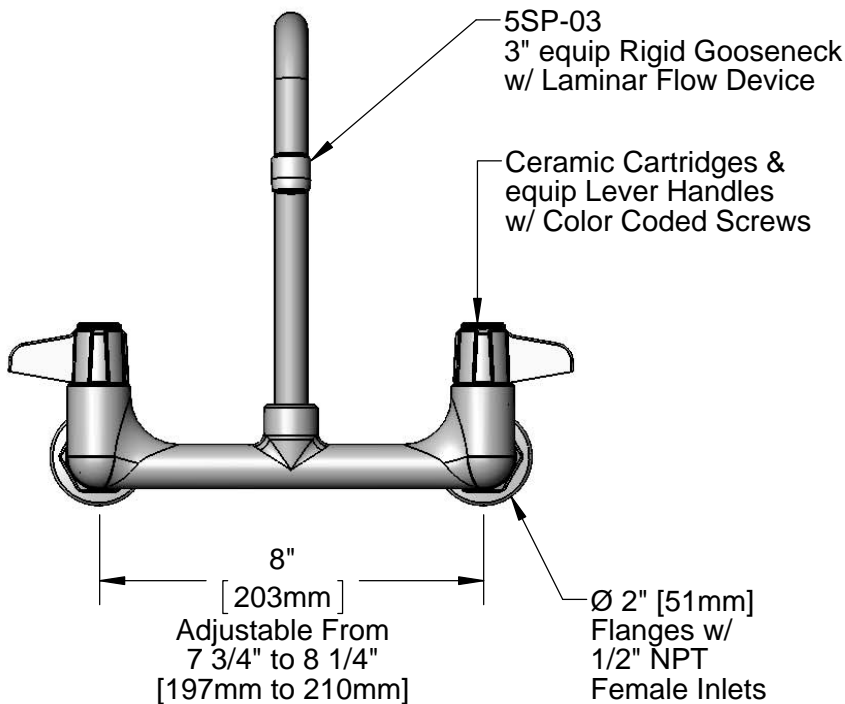
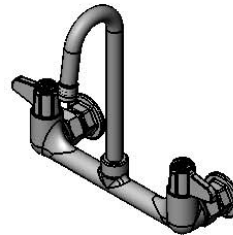
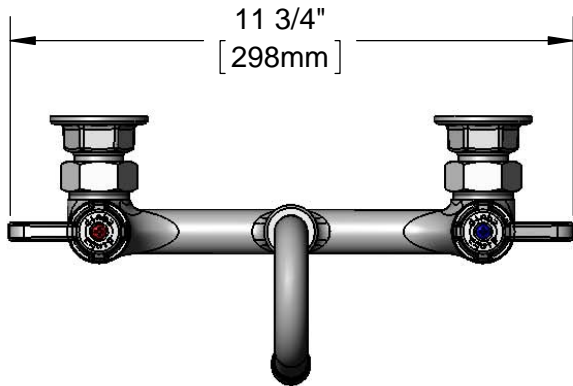

Model Number
5F-8WLX03

Product Specifications:
8" Wall Mount Mixing Faucet, Ceramic Cartridges, equip Lever Handles, 3" equip Rigid Gooseneck & 1/2" NPT Female Inlets

Product Compliance:
ASME A112.18.1 / CSA B125.1
NSF 61 - Section 9
NSF 372 (Low Lead Content)
ANSI A117.1 (ADA)

equip Foodservice Accessories  **equip**
by 

2 Saddleback Cove, P.O. Box 1088
Travelers Rest, South Carolina 29690
Phone: 800.891.4808 Fax: 800.868.0084
equip.tsbrass.com

ITEM NO.	SALES NO.	DESCRIPTION
1	5SP-03	3" equip Rigid Gooseneck
2	014250-45	Laminar Flow Device
3	5-HDL-L	equip Lever Handle w/ Color Coded Screws
4	00AA	1/2" NPT Female Eccentric Flange
5	001019-45	Coupling Nut Washer
6	013788-45	equip Ceramic Cartridge, LTC
7	013787-45	equip Ceramic Cartridge, RTC

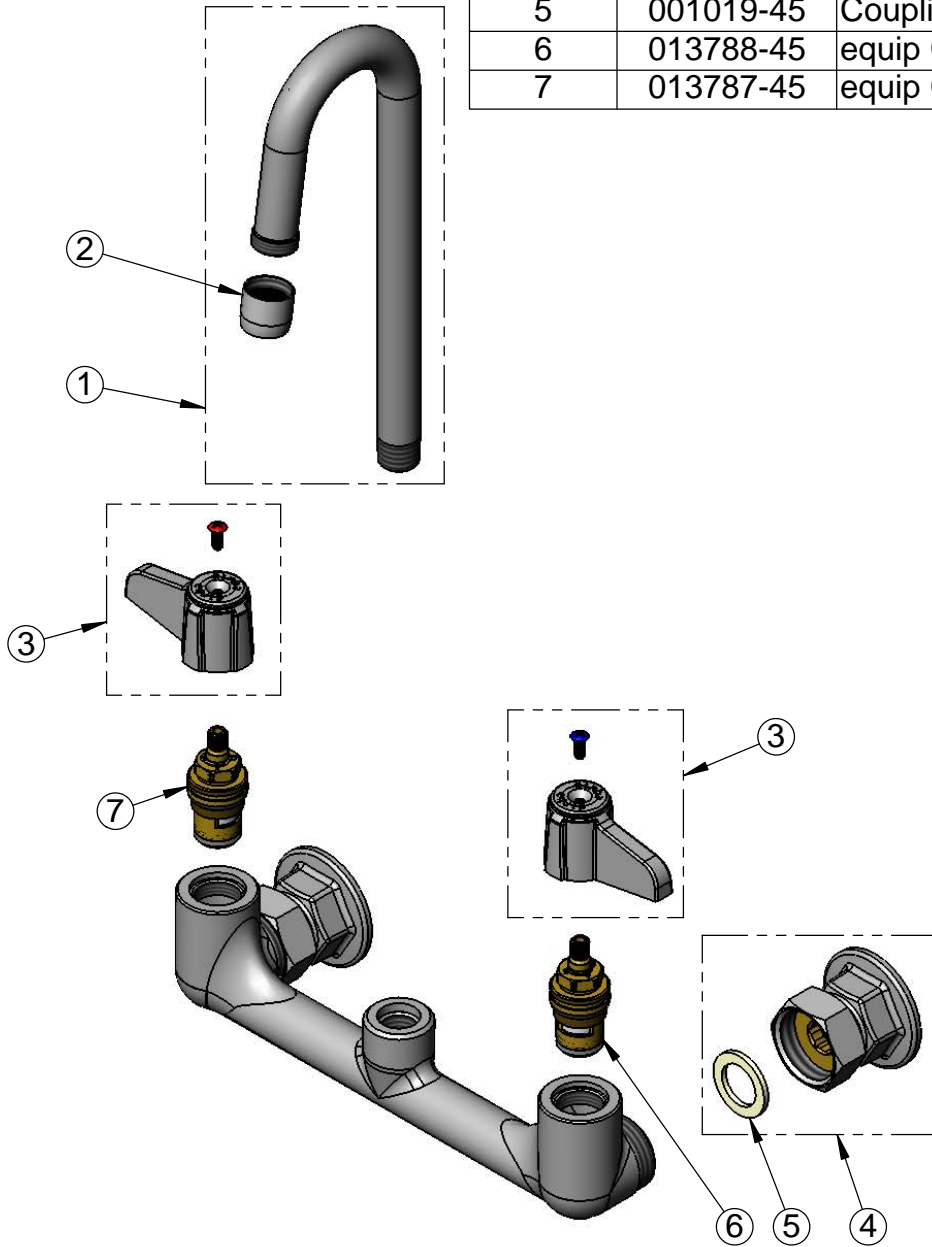

Model Number

5F-8WLX03

Product Specifications:

**8" Wall Mount Mixing Faucet, Ceramic Cartridges,
equip Lever Handles, 3" equip Rigid Gooseneck
& 1/2" NPT Female Inlets**

Product Compliance:

ASME A112.18.1 / CSA B125.1
NSF 61 - Section 9
NSF 372 (Low Lead Content)
ANSI A117.1 (ADA)

equip
Foodservice
Accessories

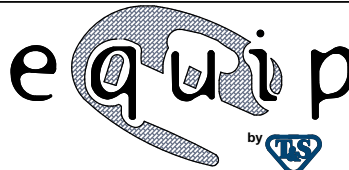

2 Saddleback Cove, P.O. Box 1088
Travelers Rest, South Carolina 29690
Phone: 800.891.4808 Fax: 800.868.0084
equip.tsbrass.com