

Ergo-One System Utility Carts

Heavy Duty Stainless Steel - 700 lb. Capacity



Model 7025

Reduce Injuries Caused By Improper Pushing, Lifting and Loading

- Shelf heights are in the safe range for repetitive loading and unloading.
- Top shelf height from the floor is 40"- 43" (1016-1092 mm), bottom shelf is 20" (508 mm).
- Vertical handles are at a comfortable height for all employees.
- All-welded stainless steel construction for added strength.
- Protective leg bumpers and comfortable handle grips are available in seven colors, blue is standard.
- Other handle and bumper colors available: Red, Green, Gray, Black, Yellow, Orange.
- Easy-to-clean and sanitize, simply wipe down or steam clean.
- NSF listed models are available.
- 700 lb. (320 kg) capacity is ideal for constant moving of heavy loads over various standard floor surfaces.

Spec. #

AIA #



Lakeside Manufacturing, Inc.

4900 West Electric Avenue • West Milwaukee, WI 53219 U.S.A.
800-558-8565 • 414-902-6400 • Fax 414-902-6446 • www.eLakeside.com

Ergo-One System Utility Carts

Heavy Duty

AutoCAD drawings available through KCL CADalog

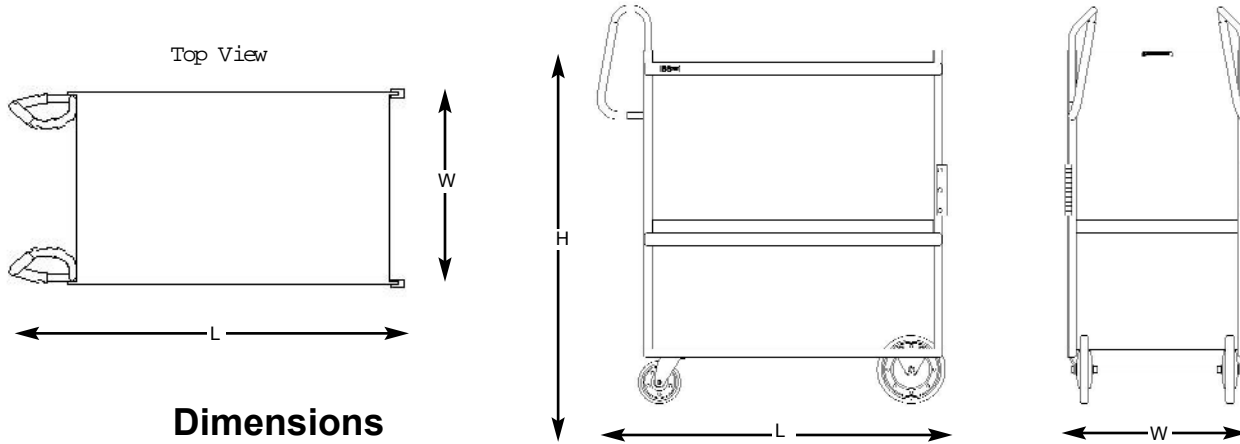

Dimensions

Model	NSF Listed Model	Shelf Description			Top Shelf Height*	Overall Size			Case Weight	
		# of	Size	Clearance		W	L	H**	lb.	(kg.)
7010	5910	2	18" x 27" (457 x 686)	18-1/2" (470)	40" (1016)	18-5/8" (473)	35-3/8" (899)	46-3/4" (1187)	53	(24)
7015	5915	3	18" x 27" (457 x 686)	10" (254)	43" (1092)	18-5/8" (473)	35-3/8" (899)	46-3/4" (1187)	63	(28.6)
7020	5920	2	21" x 33" (533 x 838)	18-1/2" (470)	40" (1016)	21-5/8" (549)	41-3/8" (1051)	46-3/4" (1187)	64	(29)
7025	5925	3	21" x 33" (533 x 838)	10" (254)	43" (1092)	21-5/8" (549)	41-3/8" (1051)	46-3/4" (1187)	78	(35.4)
7030	5930	2	21" x 49" (533 x 1245)	18-1/2" (470)	40" (1016)	21-5/8" (549)	57-3/16" (1453)	46-3/4" (1187)	87	(39.5)

Measurements in () denote metric millimeters, unless otherwise specified.

*Measured from floor.

**Includes height of ergonomic handles. Handle assembly is required.

Specifications

Unit shall be of fully welded stainless steel construction. Legs and frame shall be of .120 x 1" x 1" angle stainless steel and shall be joined with a continuous arc weld. Shelves shall be of 18-gauge stainless steel, and shall be welded to vertical leg frames. Shelves shall be double hemmed on all four edges for extra rigidity. Bottom shelf shall be positioned no closer than 20" (508 mm) from the floor surface, and top shelf shall be positioned no higher than 43" (1092 mm) from the floor surface. Push handles shall be of ergonomic vertical design and shall feature 8" range grip height. Unit shall have two each 5" (127 mm) diameter extra-load swivel casters with 1-1/4" (32 mm) wide non-marking polyurethane wheels and two each 8" diameter extra-load wheels mounted to a fixed axle. Swivel casters shall be plate type and shall be bolted to an 18-gauge 5" wide stainless steel cross member with a galvanized reinforcement. Unit shall have two each 6" (152 mm) vertical bumpers riveted to front legs.

Optional Accessories

- Extended perimeter bumper
- All 5" swivel casters
- Color coded handle grips and leg bumpers
- Set of two each 5" brake casters



Lakeside Manufacturing, Inc.

4900 West Electric Avenue • West Milwaukee, WI 53219 U.S.A.

800-558-8565 • 414-902-6400 • Fax 414-902-6446 • www.eLakeside.com