

Item # \_\_\_\_\_

Project: \_\_\_\_\_

Qty: \_\_\_\_\_

\*AutoCad available on KCL

# F-300/500BAF

## SELF-CONTAINED FLAKER WITH BUILT-IN STORAGE

F-300/500BAF

6/11

Item # 13142

### FLAKER DIMENSIONS

W x D x H

**F-300BAF**  
36 x 24 x 39\*  
\*with 6" legs

**F-500BAF**  
38 x 29 x 42\*  
\*with 6" legs

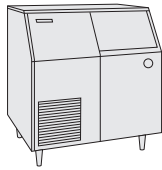

F-300BAF

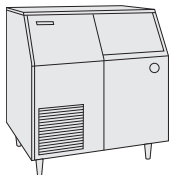

F-500BAF

### F-300BAF

Air-Cooled

### F-500BAF

Air-Cooled  
Shown



### F-300BAF

- Up to 303 lbs. of ice production per 24 hours
- Up to 110 lbs. built-in storage

### F-500BAF

- Up to 501 lbs. of ice production per 24 hours
- Up to 250 lbs. built-in storage

### F-300BAF & F-500BAF

- Designed for long life dependability
- Corrosion resistant stainless steel
- Automatic system flush when bin control is activated
- Gear motor protected from overload
- Removable air filter
- R-404A Refrigerant

- Scoop - Protected by *H-GUARD Plus* Antimicrobial Agent 



ISO9001-15014:2001

### Warranty

Valid in United States, Canada, Puerto Rico, & U.S. Territories. Contact factory for warranty in other countries.

**Three Year** - Parts & Labor on entire machine. (Serial numbers Vxxxxxj and after.)

**Five Year** - Parts on: Compressor, air-cooled condenser coil.



# Hoshizaki

## SELF-CONTAINED FLAKER WITH BUILT-IN STORAGE BIN

### F-300/500BAF

#### DIMENSIONS

W x D x H

**F-300BAF**  
36 x 24 x 39"  
**F-500BAF**  
38 x 29 x 42"  
\*with 6" legs

- Air-cooled
- Air-cooled

#### F-300BAF / AIR-COOLED

Water Temp ° F.	50°	70°	90°
Air Temp ° F.	70°	303	290
	80°	267	256
	90°	236	<b>232</b>

#### F-500BAF / AIR-COOLED

Water Temp ° F.	50°	70°	90°
Air Temp ° F.	70°	501	479
	80°	439	421
	90°	386	<b>376</b>

#### UTILITY CONSUMPTION

Model Number	Approximate Electric		KWH per 100 LBS.	
	90/70	70/50	90/70	70/50
F-300BAF	651W	613W	6.7	4.8
F-500BAF	902W	842W	5.69	4.03

#### SPECIFICATIONS

Model Number	Condenser	Amperage	Min. Circuit Ampacity	Shipping Weight
F-300BAF	Air-Cooled	9.0	N/A	210 lbs.
F-500BAF	Air-Cooled	9.98	20	270 lbs.

#### STORAGE BINS

Model Number	Application Capacity
F-300BAF	Built-in 110 lb. capacity
F-500BAF	Built-in 250 lb. capacity

- Circuit breaker or fuse protects gear motor from overload.
- Gear motor runs one minute after termination of ice making to clear all ice from evaporator.

**\*F-500 does not include power cord**

#### ELECTRICAL & PLUMBING/F-300/500BAF

- 115V/60/1
- 15 amp Max Fuse Size - F-300BAF
- 20 amp Max Fuse Size - F-500BAF
- 3/8" OD copper or equivalent independent potable water supply
- 3/4" FPT independent drain connection



© HOSHIZAKI AMERICA, INC.

618 Hwy. 74 S., Peachtree City, GA 30269

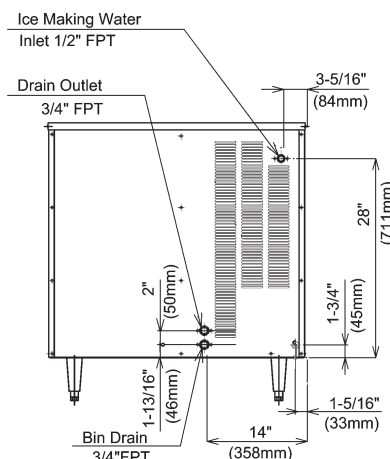
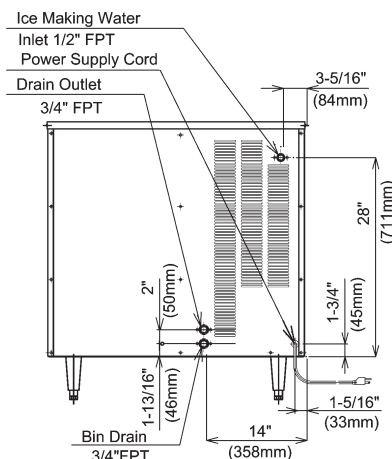
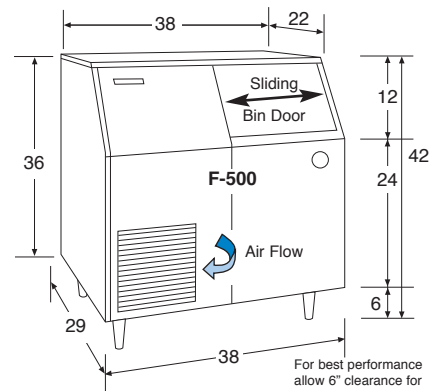
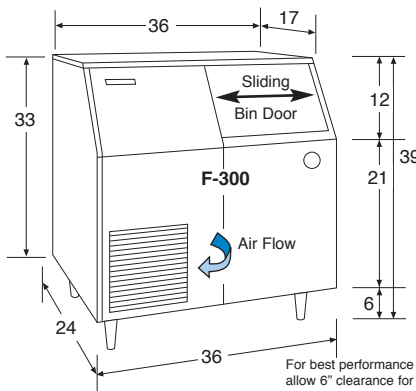

F-300 / BACK VIEW

F-500 / BACK VIEW

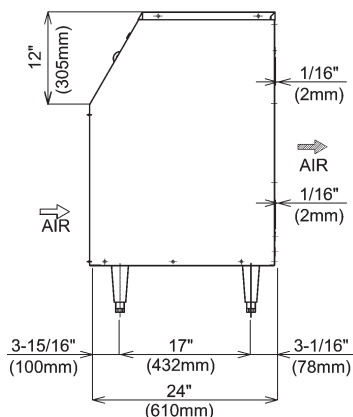

SIDE VIEW

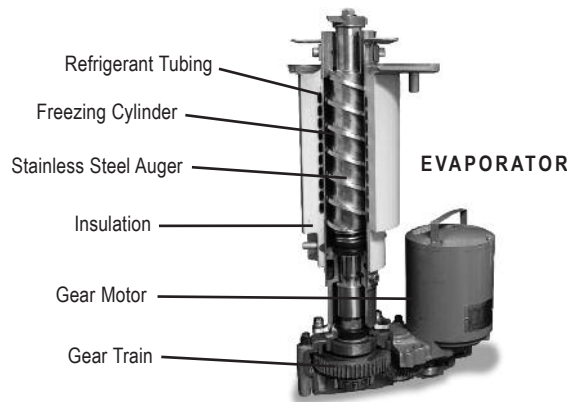

#### OPERATING LIMITS

- Ambient Temp Range 45 - 100°F
- Water Temp Range 45 - 90°F
- Water Pressure 10 - 113psig
- Voltage Range 104 - 127V

#### SERVICE

- Panels easily removed and all components accessible for service.
- Removable/cleanable air filters

TEL 1-800-438-6087

FAX 1-800-345-1325

www.hoshizaki.com

Printed in U.S.A.

