

Flav-R-Savor[®]

Curved Display Case



"Nothing less than the best."[®]



Hatco's FSCD models will take your serving area to the next level. This two shelf display case is compact yet elegant and attractively presents your foods on plates, casserole dishes, platters, or even hotel pans. Available with or without humidity.

- Hatco's signature convected air technology provides maximum holding times and peak serving temperatures for unwrapped foods
- Perforated 304 brushed annealed stainless steel shelf not only enhances air movement over food products, but looks great as well
 - Hinged, tempered front glass panel tilts forward for easy cleaning
 - Our integrated sign holder is there to help promote your product offerings (sign not included)



(800) 558-0607 • (414) 671-6350 • equipsales@hatcocorp.com or visit us at www.hatcocorp.com



Flav-R-Savor[®] CONVECTED AIR, CURVED FRONT DISPLAY CASE

Models FSCD-2PD, FSCDH-2PD

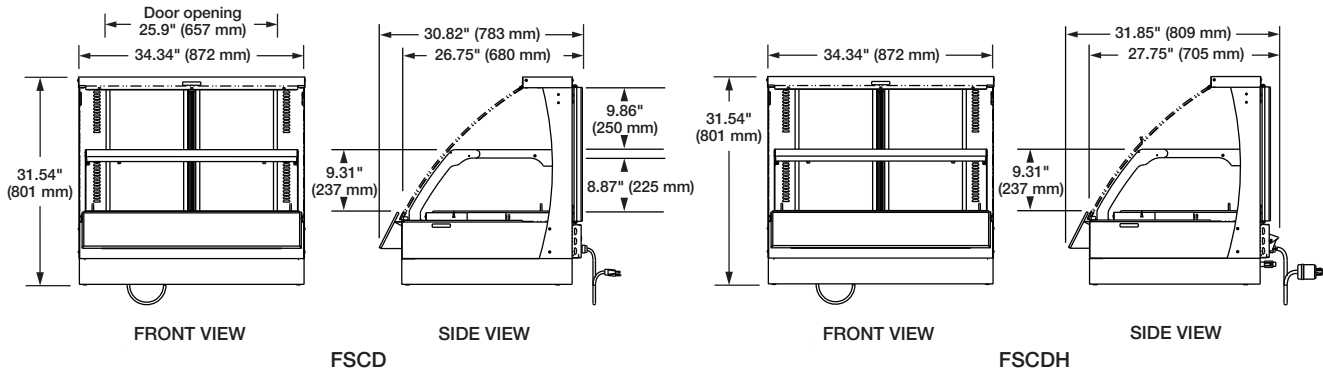

SPECIFICATIONS

Non Humidified

Model	Watts	Voltage	Shipping Weight
FSCD-2PD	1800	120	184 lbs. (84 kg)

Humidified

Model	Watts	Voltage	Shipping Weight
FSCDH-2PD	2805	120/208	190 lbs. (86 kg)
FSCDH-2PD	2805	120/240	190 lbs. (86 kg)

DIMENSIONS

FSCD-2PD:

34.34"W x 30.82"D x 31.55"H w/legs (872 x 783 x 801 mm).

FSCDH-2PD:

34.34"W x 31.85"D x 31.55"H w/legs (872 x 809 x 801 mm).

Usable Heated Shelf Space - Upper29.92"W x 15.5"D (765 x 393 mm)
- Lower.....32.12"W x 18"D (815 x 457 mm)

Water Capacity: 7 quarts (6.63 liters).

VOLTAGE

FSCD-2PD:

120, single phase, 15 Amps, NEMA 5-20P

FSCDH-2PD:

120/208-240V, single phase, 13.3 Amps, NEMA L14-20P

CORD LOCATION

Control side at right base corner.

PLUG CONFIGURATIONS

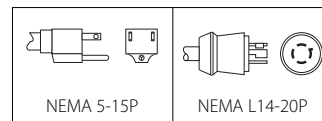

OPTIONS (NOT FOR RETROFIT)

- Designer Colors: Warm Red, Black, Gray Granite, White Granite, Navy Blue, Hunter Green, Antique Copper
- Heated Stone Colors: Gray Granite, Bermuda Sand, Night Sky (standard), Sawgrass
- Valve relocation (Humidified model only)
- Glass center shelf (in lieu of perforated stainless steel shelf)

ACCESSORIES

- 10"D x 1.25"H (254 D x 32 H mm) circular perforated riser in stainless steel

PRODUCT SPECS

Convected, Curved Front Display Case

The Convected Air, Curved Front Display Case Flav-R-Savor[®] Model ... as manufactured by the Hatco Corporation, Milwaukee, WI 53234 U.S.A.

The Display Case shall be rated at ... watts, ... volts and be ... inches (millimeters) in overall width. Thermostatically-controlled heat and humidity (FSCD-2PD models only), digital with readout or display, full view tempered glass sides, front and doors, perforated 304 brushed

annealed stainless steel upper shelf, Swanstone base shelf, overhead lights, and cord and plug.

Accessories shall include circular perforated riser and stainless steel food pans.

One year parts and labor warranty, with 24/7 parts and service assistance (U.S. and Canada only)

HATCO CORPORATION P.O. Box 340500 Milwaukee, WI 53234-0500 U.S.A. • (800) 558-0607 • (414) 671-6350
Fax (800) 543-7521 • Int'l. Fax (414) 671-3976 • www.hatcocorp.com • E-mail: equipsales@hatcocorp.com