



# EVERPURE® KLEENSTEAM® CT

TOTAL WATER TREATMENT SYSTEM FOR STEAM APPLICATIONS.

Kleensteam CT System: EV9797-50  
4CB5 Replacement Cartridge: EV9617-11  
SS-10 Cartridge: EV9799-02



## APPLICATIONS

Commercial steam  
Countertop steamers

## FEATURES • BENEFITS

Sophisticated Hydroblend compound prevents limescale formation in steam applications

System is simple to install, operate and maintain

Scalestick is NSF® Certified under NSF/ANSI Standard 42 for material requirements only

A total system delivering high quality filtered water with cleaning and deliming capabilities

Filters incoming water to improve the performance, maximize energy efficiency and increase the life of steam equipment

Reduces chlorine-induced corrosion

Easy deliming with Everpure's ScaleKleen, which is fed directly into the boiler through the SR-X bowl without boiler disassembly or the use of dangerous acids

Longer lasting SS-10 cartridge is more effective in higher alkalinity/hardness/TDS/temperature installations

## INSTALLATION TIPS

Choose a mounting location suitable to support the full weight of the system when operating

Use 3/8" water line

Connect the system to the incoming cold water boiler line only. Do not connect system to the condenser

Install vertically with cartridges hanging down

Allow 2-1/2" (6.35 cm) clearance below the cartridge for easy cartridge replacement

Flush cartridges by running water through system for five (5) minutes at full flow

## OPERATION TIPS

Change 4CB5 cartridge on a regular six (6) month preventative maintenance program

Change SS-10 cartridge before Hydroblend™ compound is completely used up

Change cartridges when capacity is reached or when pressure falls below 10 psi (0.7 bar)

Service flow rate must not exceed 1.67 gpm (6.3 Lpm)

Always flush the filter cartridge at time of installation and cartridge change

## SIZING

Service Flow Rate: Maximum 1.67 gpm (6.3 Lpm)

# EVERPURE® KLEENSTEAM® CT

## EV9797-50

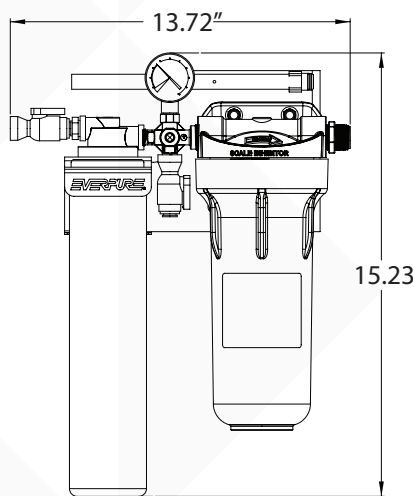

### SPECIFICATIONS

#### Overall Dimensions

15.23" L x 13.72" W x 6.23" D  
(38.6 x 34.8 x 23.5 cm)

#### Connections

Inlet Connection: 3/8"

Outlet Connection: 3/8"

#### Service Flow Rate

Maximum 1.67 gpm (6.3 Lpm)

#### Pressure Requirements

10 - 125 psi (0.7 - 8.6 bar), non-shock

#### Maximum Water Temperature at Inlet

80°F (27°C)

#### Operating Weight

18 lbs (8.1 kg)

#### Shipping Weight

15 lbs (6.8 kg)

#### Electrical Connection

None required

#### Alkalinity Range

2 to 12 grains per gallon

The contaminants or other substances removed or reduced by this drinking water system are not necessarily in your water. Do not use with water that is microbiologically unsafe or of unknown quality without adequate disinfection before or after the system. Systems certified for cyst reduction may be used with disinfected water that may contain filterable cysts.

### WARRANTY

Everpure water treatment systems by Pentair® (excluding replaceable elements) are covered by a limited warranty against defects in material and workmanship for a period of five years after date of purchase. Everpure replaceable elements (filter cartridges and water treatment cartridges) are covered by a limited warranty against defects in material and workmanship for a period of one year after date of purchase. See printed warranty for details. Pentair will provide a copy of the warranty upon request.



#### FILTRATION & PROCESSING SOLUTIONS

EVERPURE-SHURFLO WORLD HEADQUARTERS, 1040 MUIRFIELD DRIVE, HANOVER PARK, IL 60133 USA • WWW.EVERPURE.COM  
800.942.1153 MAIN (US ONLY) • 630.307.3000 MAIN • 630.307.3030 FAX • CSEVERPURE@PENTAIR.COM EMAIL

EVERPURE-SHURFLO AUSTRALIA / NEW ZEALAND, 1-21 MONASH DRIVE, DANDENONG SOUTH, VIC, 3175, AUSTRALIA  
1300.576.190 TEL • AU.EVERPURE@PENTAIR.COM EMAIL

EVERPURE-SHURFLO CHINA, 21F CLOUD 9 PLAZA, NO 1118, SHANGHAI, 200052, CHINA  
86.21.3211.4588 TEL • 86.21.3211.4580 FAX • CHINA.WATER@PENTAIR.COM EMAIL

EVERPURE-SHURFLO INDIA, GREEN BOULEVARD, B-9/A, 7TH FLOOR - TOWER B SECTOR 62, NOIDA - 201301  
91.120.419.9444 TEL • 91.120.419.9400 FAX • INDIACUSTOMER@PENTAIR.COM EMAIL

EVERPURE-SHURFLO EUROPE, PENTAIR WATER BELGIUM BVBA, INDUSTRIEPARK WOLFSTEE, TOEKOMSTLAAN, 30 B-2200 HERENTALS, BELGIUM  
+32.(0).14.283.500 TEL • +32.(0).14.283.505 FAX • SALES@EVERPURE-EUROPE.COM EMAIL

EVERPURE-SHURFLO JAPAN INC., HASHIMOTO MN BLDG. 7F, 3-25-1 HASHIMOTO, MIDORI-KU, SAGAMIHARA-SHI KANAGAWA 252-0143, JAPAN  
81.(0)42.775.3011 TEL • 81.(0)42.775.3015 FAX • INFO@EVERPURE.CO.JP EMAIL

EVERPURE-SHURFLO SOUTHEAST ASIA, 390 HAVELOCK ROAD, #04-01, KING'S CENTRE, SINGAPORE 169662  
65.6795.2213 TEL • FAX: 65.6795.2219 FAX • CSEVERPURE@PENTAIR.COM EMAIL

All Pentair trademarks and logos are owned by Pentair, Inc. All other brand or product names are trademarks or registered marks of their respective owners. Because we are continuously improving our products and services, Pentair reserves the right to change specifications without prior notice. Pentair is an equal opportunity employer.