



Portable Filters

Project _____
 Item _____
 Quantity _____
 CSI Section 11400 _____
 Approval _____
 Date _____

Portable Filters

Models

PF50S

PF50R



Standard Features

- 50-lb. capacity
 - 4 GPM, 1/3 HP heavy-duty pump
 - Fast - filters a 50-lb. fryer in 5 minutes
 - Filters from bottom leaving minimal heel oil
 - Stainless steel filter pan and pump assembly housing
 - Cover and fold-down handle for safe and easy storage
 - Steel frame mounted on four swivel casters allows for easy movement
 - Heated suction line keeps the return line open and oil free flowing
 - Nickel plated steel wand assembly with non-heat conducting handle efficiently returns filtered oil to frypot
- Filtration powder sample and 25 sheets filter paper

Options & Accessories

Crumb tray

Specifications

Specifically designed to filter oil from any 50-lb Frymaster or Dean Fryer

Frymaster portable filters are easy to use and are specifically designed to preserve oil life by filtering out sediment and oil breakdown products, maximizing oil life and contributing to the consistent production of great tasting fried foods.

Standard 12" x 18" (305 x 457 mm) Filter Magic® filter paper and Filter Magic powder are required to effectively filter 50 lbs. of oil in five minutes from start to finish.

Nothing preserves oil life and ensures the quality of fried foods better than regular oil filtration. The by-products created by high-heat frying take a toll on oil life unless a daily system of filtration and cleaning removes them.

Independent heat keeps the suction line open and oil free flowing. The filter wand is durable and efficiently flushes crumbs and residue from the frypot.

The PF50R model comes with a reversible pump which can be used to both remove oil and refill any manufacturer's 50-lb fryer.



8700 Line Avenue
Shreveport, LA 71106-6800
USA

Tel: 318-865-1711
Tel: 1-800-221-4583
Fax: 318-868-5987
E-mail: info@frymaster.com

www.frymaster.com
Bulletin No. 818-0092 11/07



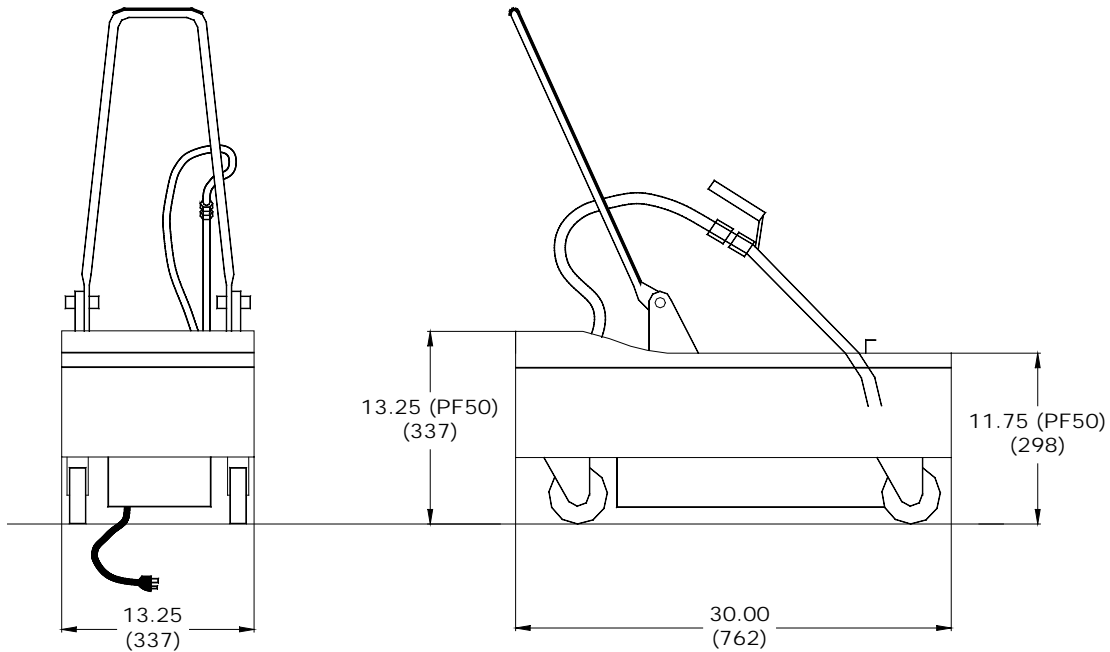

PORTABLE FILTER (PF50 SHOWN)

DIMENSIONS

MODEL NO.	OIL CAPACITY	OVERALL SIZE (cm)			DRAIN HEIGHT	APPROXIMATE SHIPPING INFORMATION						
		HEIGHT	WIDTH	LENGTH		WEIGHT	CLASS	CU. FT.	DIMENSIONS			
PF50S and PF50R	50 lbs. (28 liters)	13.25" (337 mm)	13.25" (337 mm)	30" (762 mm)	11.75" (296 mm)	85 lbs. (39 kg)	85	7.63	H 25" (635 mm)	W 16.75" (425 mm)	L 31.50" (800 mm)	

Hose is 66-1/2" (1689 mm) long, wand is 25" (635 mm) long.
Cord is 61" (1549 mm) long.

POWER REQUIREMENTS

- 1/3 H.P., 120V - 60 Hz 9 Amp
- 230 VAC 50 Hz. 5 Amp

NOTES

Filters 50-lbs. of liquid shortening in 5 minutes. Independent heat control keeps piping open and free flowing when solid shortening is used.

HOW TO SPECIFY

- PF50S 50-lb. capacity standard, gravity drain
- PF50R 50 lb. capacity, reversible pump