

ICFC Series Curved Lid Display Freezer

REFRIGERATION
AVANTCO

www.AvantcoRefrigeration.com

MODEL #360ICFC9HC

ICFC SERIES - CURVED LID DISPLAY FREEZER

Perfect for merchandising frozen foods.

CABINET CONSTRUCTION

Sturdy design features white powder-coated steel exterior and embossed aluminum interior.

Foamed-in-place CFC- and HCFC-free polyurethane insulation enhances the structural integrity of the cabinet and promotes energy efficiency.

Glass lid provides constant product visibility to reduce energy loss from repeatedly opening the unit.

REFRIGERATION SYSTEM

Environmentally-safe R290 refrigerant. Rear-mounted condensing unit positioned for easy maintenance.

BASKETS

2 coated-wire baskets included to organize products.

MODEL FEATURES

2" diameter casters provide mobility for easy cleaning and service.

Drain plug located on backside of unit.

SPECIAL FEATURES

- 7.4 cu. ft. of frozen storage space
- Glass lid for product visibility
- 2 coated-wire baskets for organized storage
- Foamed-in-place polyurethane insulation
- Manual temperature controls hold at -13 - 0°F
- Environmentally-friendly R290 refrigerant
- White powder-coated steel exterior
- Embossed aluminum interior
- Drain plug on back of unit
- (4) 2" casters simplify mobility and maintenance
- 1/5 hp compressor



WARRANTY

RESIDENTIAL: Avantco assumes no liability for parts or labor coverage for component failure, factory defect or any other damages for units installed in non-commercial foodservice or residential applications.



Replacement

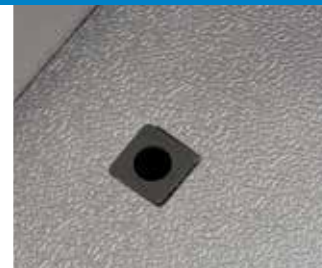

ICFC Series Curved Lid Display Freezer

MODELS #360ICFC9HC



www.AvantcoRefrigeration.com

TECHNICAL DATA

Dimensions

Exterior Dimensions	40 ⁵ / ₈ "W x 24 ³ / ₈ "D x 34 ¹ / ₄ "H (Includes 2" Diameter Casters)
Interior Dimensions	35 ¹ / ₄ "W x 19"D x 26 ³ / ₄ "H (Excludes Compressor)
Net Volume	7.4 cu. ft.
Net Weight	115 lb.
Gross Weight	137 lb.
Packing Dimensions	43 ¹ / ₄ "W x 27 ¹ / ₄ "D x 39"H

Cooling

Temperature Range	-13° - 0°F
Refrigerant	R290
Max. Ambient Temperature	90°F
Defrosting	Manual
Temperature Controller	Manual
Horsepower	1/5

Construction

Exterior Material	White Powder Coated Steel
Interior Material	Embossed Aluminum
Insulation Material	Foamed-in-place Polyurethane
Baskets	(2) 17 ¹ / ₂ " x 10 ¹ / ₂ " x 9"
Basket Material	Coated Wire
Drain Plug	Located On Back Side

Electrical

Voltage	115
Amps	2.5
Hz	60
Phase	1
Plug Type	NEMA 5-15P
Electrical Cord Length	80"

PLAN VIEW

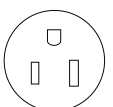
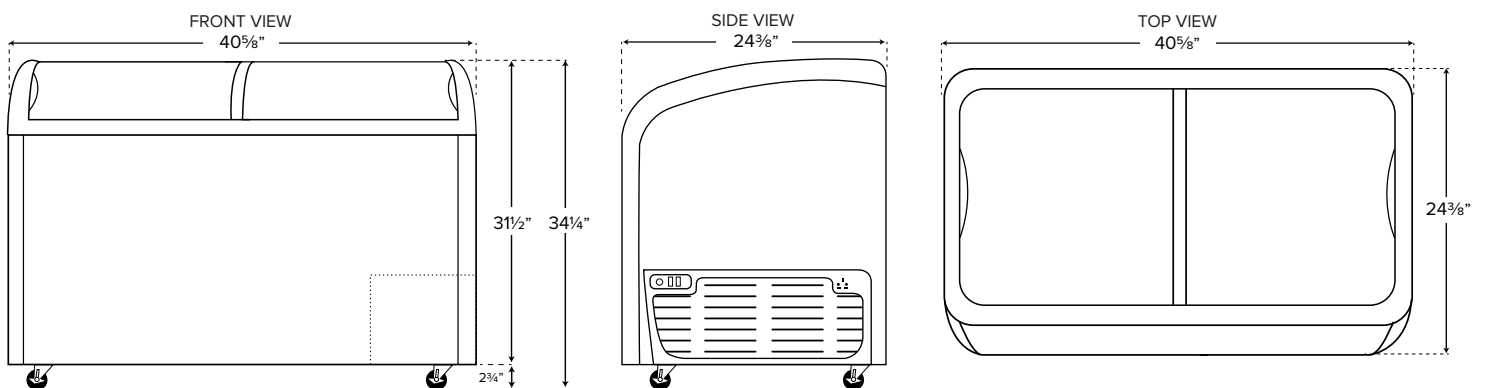

NEMA 5-15P