

# ADC Series Ice Cream Dipping Cabinet

REFRIGERATION  
**AVANTCO**

[www.AvantcoRefrigeration.com](http://www.AvantcoRefrigeration.com)

**MODEL #360ADC8CHC**

## ADC SERIES - DIPPING CABINET WITH CURVED SNEEZE GUARD

Great for displaying, merchandising and serving a delicious variety of ice cream flavors.

### CABINET CONSTRUCTION

Easily assembled curved glass sneeze guard enhances product visibility and prevents contamination. Sturdy design features white powder-coated steel exterior and painted steel interior.

Foamed-in-place CFC- and HCFC-free polyurethane insulation enhances the structural integrity of the cabinet and promotes energy efficiency. Locking glass lid provides constant product visibility to showcase a variety of ice cream flavors.

### REFRIGERATION SYSTEM

Environmentally-safe R290 refrigerant. Side-mounted condensing unit for side and rear ventilation. Cold wall design prevents cold air from escaping.

### STORAGE

Displays (8) 3-gallon tubs of ice cream at the perfect height for service. Additional storage for (6) 3-gallon tubs underneath.

### MODEL FEATURES

Curved glass sneeze guard and contoured cabinet design add modern appearance, perfect for showcasing and serving ice cream. Pre-drilled holes for dipper well installation on back of the cabinet.

2" diameter casters provide mobility for easy cleaning and service. Drain plug located on backside of unit.

## SPECIAL FEATURES

- Displays up to 8 ice cream tubs; space beneath display to store up to 6 back-up tubs
- Includes curved-front sneeze guard that ensures visibility and prevents contamination
- Holds temperatures between -13 and 0°F; manual temperature control
- Environmentally-safe R290 refrigerant; manual defrost feature
- Perfect for ice cream shops, dessert bars, and cafeterias
- 115V, 2/5 hp



## WARRANTY

RESIDENTIAL: Avantco assumes no liability for parts or labor coverage for component failure, factory defect or any other damages for units installed in non-commercial foodservice or residential applications.



Replacement



# ADC Series Ice Cream Dipping Cabinet

MODEL #360ADC8CHC



[www.AvantcoRefrigeration.com](http://www.AvantcoRefrigeration.com)

## TECHNICAL DATA

### Dimensions

Exterior Dimensions	49 <sup>5</sup> / <sub>8</sub> "W x 28 <sup>1</sup> / <sub>8</sub> "D x 52 <sup>1</sup> / <sub>8</sub> "H
Interior Dimensions	43 <sup>3</sup> / <sub>4</sub> "W x 24 <sup>1</sup> / <sub>4</sub> "D x 26 <sup>1</sup> / <sub>8</sub> "H
Net Volume	10.25 cu. ft.
Net Weight	238 lb.
Gross Weight	271 lb.
Packaging Dimensions	52 <sup>1</sup> / <sub>2</sub> "W x 30"D x 37 <sup>1</sup> / <sub>2</sub> "H + 50 <sup>3</sup> / <sub>4</sub> " x 10 <sup>3</sup> / <sub>4</sub> " x 27 <sup>1</sup> / <sub>2</sub> "
Tubs Displayed	8
Tubs Stored	6

### Cooling

Temperature Range	(-13) - 0°F
Refrigerant	R290
Max. Ambient Temperature	90°F
Defrosting	Manual
Temperature Controller	Manual
Horsepower	2/5
BTU	1091

### Construction

Exterior Material	Painted Steel
Interior Material	Painted Steel
Insulation Material	Foamed-In-Place Polyurethane
Sneeze Guard Material	Tempered Glass
Tub Holder Material	Painted Steel

### Electrical

Voltage	115
Amps	4
Hz	60
Phase	1
Plug Type	NEMA 5-15P
Electrical Cord Length	70"

## PLAN VIEW

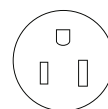
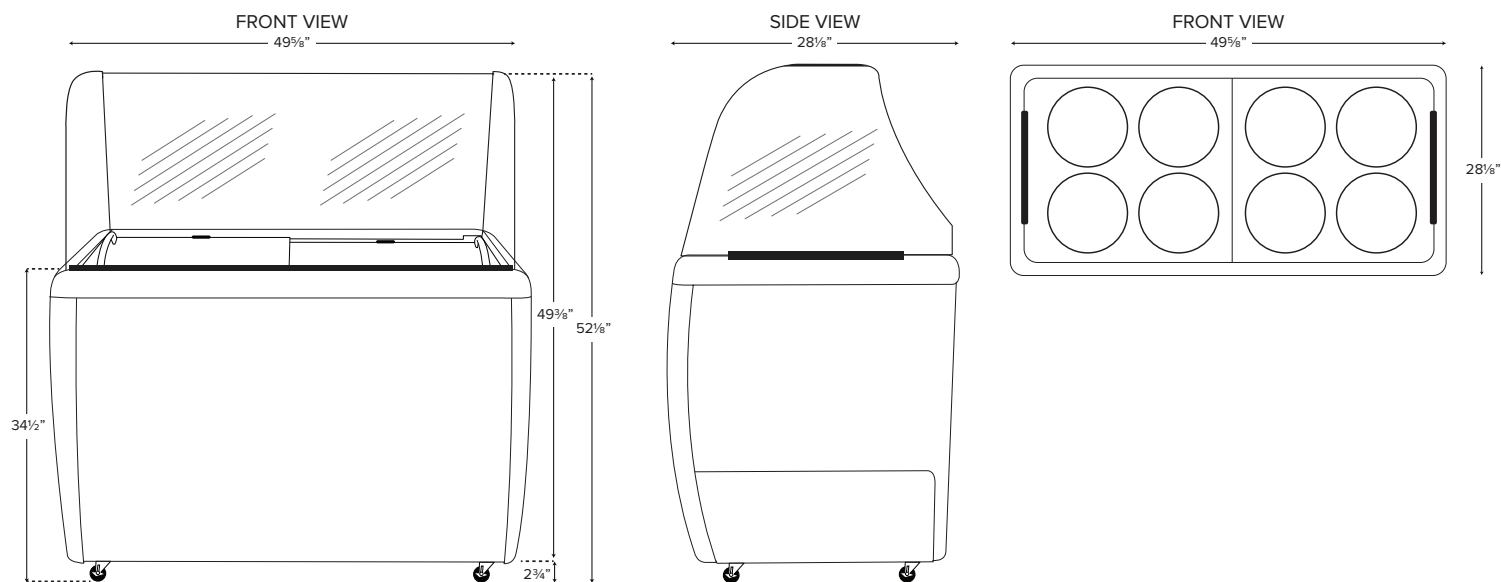

NEMA 5-15P