

APPLICATION:

PRODUCT NAME:
PRE-RINSE SPRG SINGLE DECK DUAL CTL WITH WALL BRACKET & ADD-ON FAUCET

JOB NAME:

_____ SPECIAL CONFIGURATION

QUANTITY:

ITEM NO.:

MODEL:

- 34169 WITH 6" SWING SPOUT
- 34177 WITH 8" SWING SPOUT
- 34185 WITH 10" SWING SPOUT
- 34193 WITH 12" SWING SPOUT
- 34207 WITH 14" SWING SPOUT
- 34215 WITH 16" SWING SPOUT

OPTIONS OR MODIFICATIONS:

- SUPPLY LINES (24" OR 36") CIRCLE LENGTH
- BACKFLOW PREVENTER
- BRUSH
- VANDAL RESISTANT KIT
- HANDLES (CROSS OR WRIST) CIRCLE STYLE
- OTHER _____

FEATURES:

- MAIN CONTROL VALVE**
- * SINGLE DECK, DUAL CONTROL
 - * INTERNAL SPRING LOADED CHECK VALVES
 - * SWIVELING SEAT DISKS
 - * HOT SIDE STEM - RIGHT HAND CHECK
 - * COLD SIDE STEM - LEFT HAND CHECK
 - * STAINLESS STEEL SEATS, SEAT SCREWS AND HANDLE SCREWS

- ADD-ON CONTROL VALVE**
- * STEM - RIGHT HAND SWIVEL
 - * HOT INDEX BUTTON
 - * SWIVELING SEAT DISKS
 - * STAINLESS STEEL SEATS, SEAT SCREWS AND HANDLE SCREWS.

- HOSE**
- * 36" LENGTH
 - * STAINLESS STEEL END FITTINGS
 - * STAINLESS STEEL EXTERNAL JACKET
 - * 3-PLY FIBER REINFORCED INTERNAL RUBBER HOSE
 - * REPAIRABLE IN FIELD WITH SIMPLE TOOLS

- ULTRA SPRAY VALVE**
- * LOWEST ENERGY USER - 1.15 GPM @ 60 PSI
 - * CLEANS FASTER - TEST PROVEN
 - * ENGINEERED TO LAST - NO 'O' RINGS TO LEAK
 - * INTERCHANGEABLE - FITS ALL BRANDS

- WALL BRACKET**
- * ADJUSTS FROM 2" TO 12"

- SYSTEM LIMITS**
- * TEMP: 40 F MIN. TO 140 F MAX. STATIC
 - * PRESSURE 200 PSI MAX. STATIC
 - * SHIPPING WEIGHT: 15.0 LBS

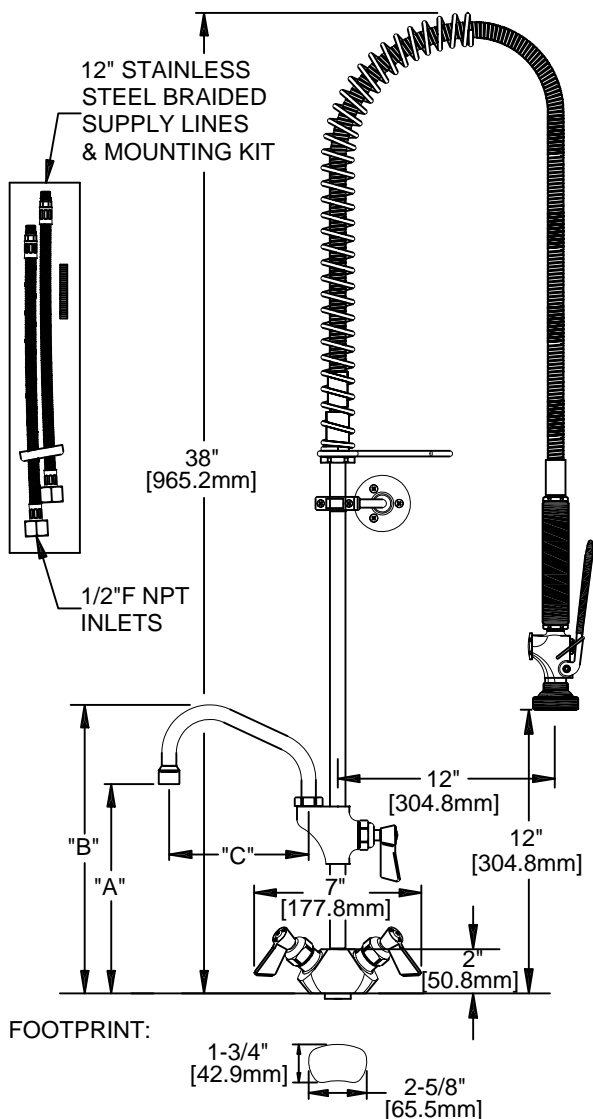

FOOTPRINT:

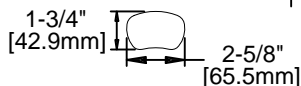

ROUGH-IN	MODEL	DIM "A"	DIM "B"	DIM "C"
 1-1/4" [31.8mm]	34169	8-3/4" [221.3mm]	12-3/8" [313.3mm]	6" [152.4mm]
	34177	9" [227.6mm]	12-7/8" [326.0mm]	8" [203.2mm]
	34185	9-5/8" [243.5mm]	13-3/8" [340.3mm]	10" [254.0mm]
	34193	10-1/4" [259.4mm]	13-7/8" [351.4mm]	12" [304.8mm]
	34207	10-7/8" [275.2mm]	14-3/4" [373.7mm]	14" [355.6mm]
	34215	11-5/8" [294.3mm]	15-3/8" [389.5mm]	16" [406.4mm]



FISHER MANUFACTURING COMPANY
 TOLL FREE: 800-421-6162 - FAX: 800-832-8238
 information@fisher-mfg.com - www.fisher-mfg.com

