



BEVERAGE-AIR

Project: _____

AIA#

Item: _____

Location: _____

SIS#

Approved: _____

WTRCS72D-1 COOKSTAND REFRIGERATOR

MODEL:
WTRCS72D-1

WTRCS72D-1 Worktop Refrigerator with 4 Drawers

WTRCS72D-1 Refrigerator with 4 Drawers: Food Prep Series

3 Year Parts/Labor Warranty
Additional 2 Year Compressor Warranty

CABINET CONSTRUCTION



WTRCS72D-1

- Stainless steel front, sides, drawer(s), and grille (galvanized back & bottom)
- Full electronic control
- Drawers provide ample food product storage
- Full marine drip-guard to prevent spills from dripping over the edge
- Interior liner is made of corrosion resistant aluminum
- Dynamic load rating of 275 lbs per drawer
- 12 gauge drawer slides with 3 Delrin encased stainless steel roller bearings per each drawer slides - *LIFETIME WARRANTY ON ALL DRAWERS AND SLIDES*
- Heavy duty, fire-proof, reinforced insulated 16 gauge top
- Accommodates 6" deep pans in top & bottom drawers
- Self-closing feature engages in the last 1-2" of travel
- 6" Casters, 3 with brakes standard

OPTIONS & ACCESSORIES

- 6" Legs
- 3" Casters
- Gasket guards
- Remote option
- Worktop sizes options
- Flat top option

REFRIGERATION SYSTEM

- Refrigeration system uses R134a refrigerant to comply with all environmental concerns
- Automatic, non-electric evaporator
- Epoxy coated evaporator coil



3779 Champion Blvd., Winston-Salem, NC 27105
1-888-845-9800 Fax: 1-336-245-6453
Beverage-Air.com sales@bevair.com



BEVERAGE-AIR

MODEL	WTRCS72D-1
EXTERNAL DIMENSIONAL DATA	
Width Overall (Cabinet)	72"
Depth Overall with Handle & Bumper	34 3/4"
Height Overall with 6" Casters	26 5/8"
Number of Drawers	4
Depth with Drawer Extended	57 3/4"
Drawer Opening (in)	Upper 27 3/8" x 6 1/2" (R) Lower 27 3/8" x 6 1/2" (L)
INTERNAL DIMENSIONAL DATA	
Internal Width Overall (in)	58"
Internal Depth Overall (in)	26"
Internal Height Overall (in)	16"
ELECTRICAL DATA	
Full Load Amperes 115/60/1	4.5A
REFRIGERATION DATA	
Horsepower	1/3
Capacity (BTU/Hr)*	1690
WEIGHT DATA	
Gross Weight (Crated lbs)	580 lbs
Height - Crated	26"
Width - Crated	75 1/2"
Depth - Crated	38"

Drawers

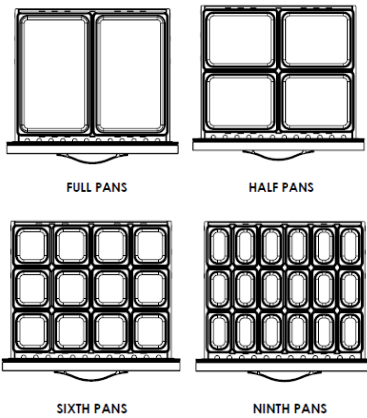

Worktop Refrigerator– With 4 Drawers

Models: WTRCS72D-1

Model Views

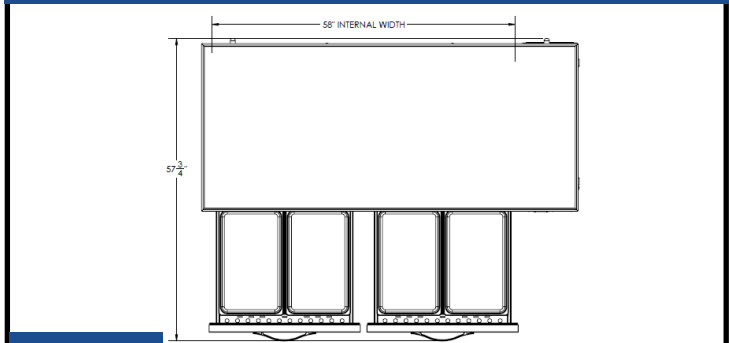

Plan View

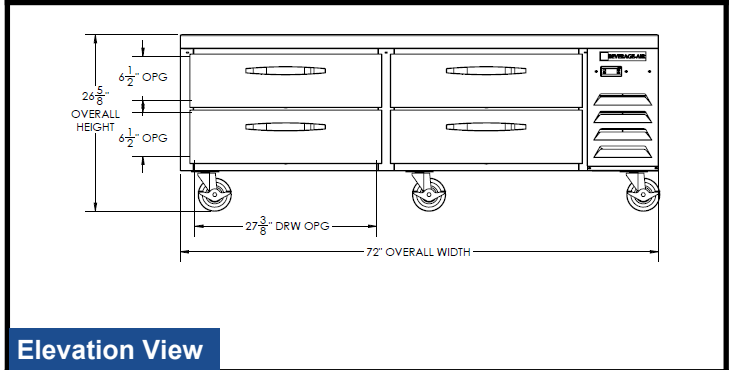

Elevation View

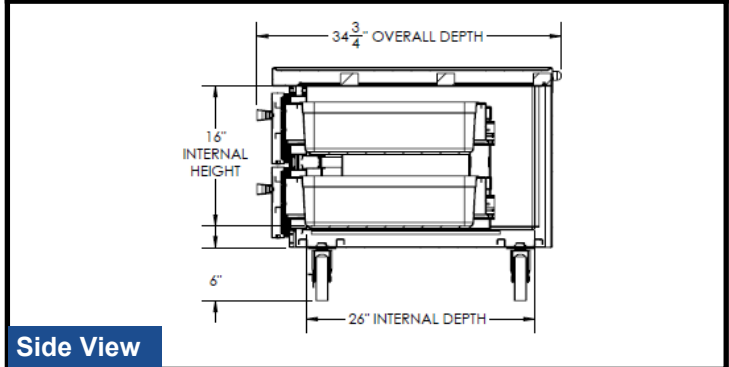

Side View

ELECTRICAL CONNECTION

Units pre-wired at factory and include 8' long cord and plug set.



115/60/1
NEMA-5-15P



an Ali Group Company



The Spirit of Excellence

3779 Champion Blvd., Winston-Salem, NC 27105
1-888-845-9800 Fax: 1-336-245-6453
Beverage-Air.com sales@bevair.com