



BEVERAGE-AIR

3779 Champion Blvd., Winston-Salem, NC 27105
1-888-845-9800 Fax# 1-336-245-6453
<http://www.Beverage-Air.com>

Commercial Refrigeration Equipment General Specification

3 Year Parts/Labor Warranty Additional 2 Year Compressor Warranty

UCF-SERIES UNDERCOUNTER UNITS

Versatile, compact (29" deep) models for undercounter and work-top applications for refrigerated/frozen storage of food products. **Refrigerator** and **Freezer** functions located within the same cabinet. Height is 34-1/2".

CABINET CONSTRUCTION

Heavy duty construction includes exterior stainless steel on front, sides, door(s) and grille. Cabinet back and bottom are galvanized steel. Interior liner is made of corrosion resistant aluminum. Interior thermometer is standard.

Cabinets are insulated with 2" thick foamed-in-place polyurethane insulation. Sub-top insulated with 1-1/2" foamed-in-place polyurethane insulation. Field-reversible doors are mounted to cabinet on self-closing, cartridge style hinges with 120° stay open feature. **Freezer** section door openings include low wattage, anti-condensate heaters. Doors are equipped with a snap-in-place vinyl magnetic gasket for positive seal. Convenient, double pull style door handle is made of black anodized aluminum. 6" high casters are standard, 2 include brakes. Interior arrangement includes 2 steel wire epoxy coated shelves behind each door, adjustable in 1/2 inch increments.

REFRIGERATION

Refrigerator

Forced-air refrigeration system utilizes R134a refrigerant metered by a capillary tube system. Automatic (non-electric) condensate evaporator is standard. Interior forced air system, with high humidity evaporator coils, provides the ideal environment for food preservation.

Freezer

Forced air refrigeration system use capillary tube to meter refrigerant. Temperatures are held at 0°F and below. Refrigerant used is R404A. Automatic defrost is standard. Automatic (non-electric) condensate evaporator is provided.

ELECTRICAL

Units wired at factory and ready for connection to a 115/60/1 phase, 15 amp dedicated outlet. 8' long cord and plug set included.

Item No. _____
Quantity _____

UNDERCOUNTER DUAL-TEMP REFRIGERATOR/FREEZER 29" BASE MODEL SERIES

MODELS:
UCRF50A
UCRF52A



UCRF50A



UCRF52A

SPECIAL FEATURES

- Flexible door configurations (see page 2)
- Field-reversible doors
- Cartridge style door hinges provides positive seal & eliminates door sagging issues (excludes some special units).
- 6" casters, two with brakes standard.
- Optional 6" legs or 3" casters available (ADA)

ELECTRICAL CONNECTION

Units pre-wired at factory and include 8' long cord and plug set.



115/60/1
NEMA-5-15P

Available From:



Model Specified _____	Store# _____
Location _____	Quantity _____



BEVERAGE-AIR

Standard Undercounter Dual-Temp Refrigerator/Freezer Cabinets
Models: UCRF50A, RF52A

MODEL	UCRF50A	UCRF52A
EXTERNAL DIMENSIONAL DATA		
Length Overall (inches) Length Overall (mm)	50" 1270	52" 1321
Depth Overall (inches) - Less handle w/bumpers Depth Overall (mm) - Less handle w/bumpers	29 1/4" 743	29 1/4" 743
Height Overall—on 6" casters (inches) Height Overall—on 6" casters (mm)	34 1/2" 876	34 1/2" 876
Depth with Door Open 90 °	52 1/4"	52 1/4"
Clear Door Opening (inches)	19 1/2" x 21 1/2"	19 1/2" x 21 1/2"
Number of doors	2	2
INTERNAL DIMENSIONAL DATA		
NET Capacity (cubic ft.) NET Capacity (Liters)	14.6 413	15.0 425
Internal Length Overall (inches) Internal Length Overall (mm)	44" 1118	46" 1168
Internal Depth Overall (inches) Internal Depth Overall (mm)	20" 508	20" 508
Internal Height Overall (inches) Internal Height Overall (mm)	23" 584	23" 584
Number of shelves	4	4
ELECTRICAL DATA		
Full Load Amperes 115/60/1 (Refrigerator section)	4.0	4.0
Full Load Amperes 115/60/1 (Freezer section)	6.0	6.0
REFRIGERATION DATA		
Horsepower (Refrigerator section)	1/6	1/6
Horsepower (Freezer section)	1/4	1/4
WEIGHT DATA		
Gross Weight (Crated lbs)	245	245
Gross Weight (Crated kg)	111	111

PLAN VIEWS

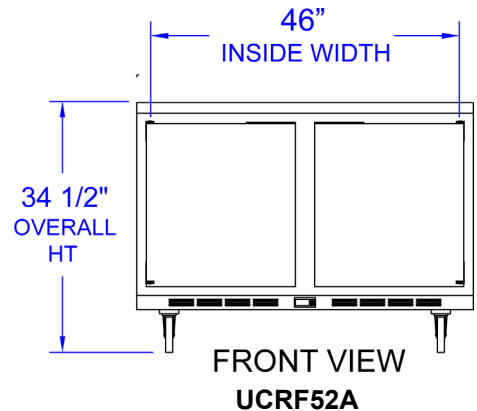
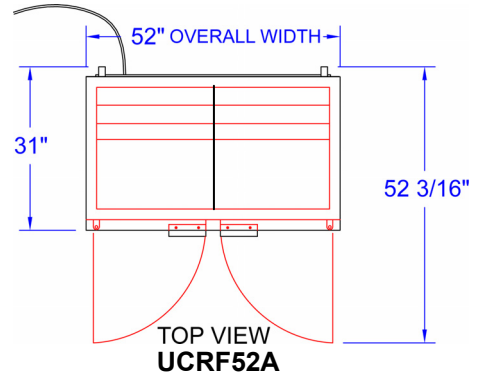
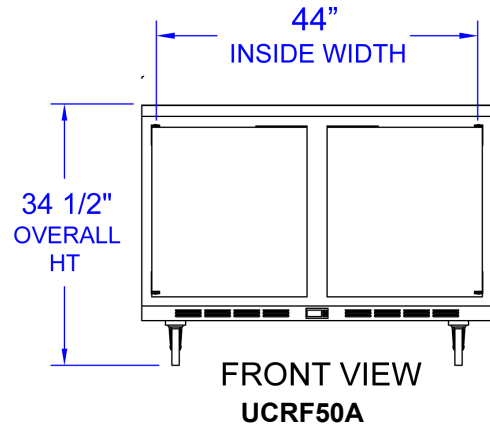
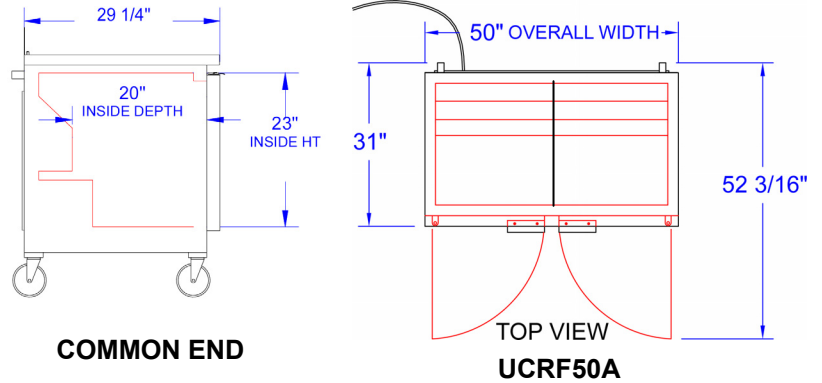

FLEXIBLE DOOR CONFIGURATIONS

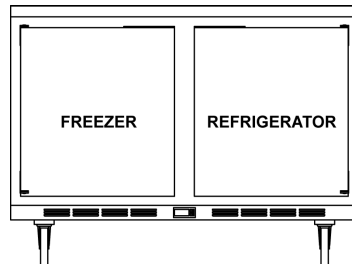
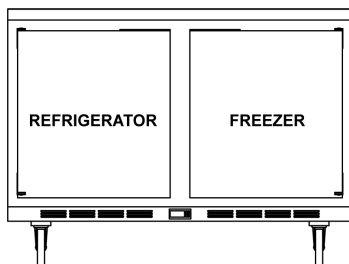

BEVERAGE-AIR® CORPORATION

3779 Champion Blvd. • Winston-Salem, NC 27105 USA • (336) 245-6400 • Fax (336) 245-6453 • (888) 845-9800 • www.beverage-air.com

Specifications are subject to change without prior notice. 06/13