



UBB Series Galvanized Top Back Bar Refrigerator

MODELS #178UBB72GTS

CABINET CONSTRUCTION

Heavy-duty stainless steel exterior with a type 201 stainless steel interior features coved corners for easy clean-up. Self-closing, solid doors come standard with locks to protect contents inside.

Foamed-in-place CFC- and HCFC-free polyurethane insulation enhances the structural strength of the cabinet and helps increase energy efficiency.

REFRIGERATION SYSTEM

Environmentally safe R290 refrigerant. Side-mounted condensing unit positioned for easy maintenance.

SHELVING

6 epoxy-coated steel shelves included. Each accommodates up to 90 lb.

MODEL FEATURES

Preprogrammed digital controller features auto-defrost function. LED lighting ensures optimal product visibility. Accommodates three ½ size kegs. Narrow depth design makes this unit ideal for tight bar spaces. Lower profile perfect for built-in bars.

PROJECT: _____

MODEL: _____ SERIAL#: _____

ITEM #: _____ QUANTITY: _____

APPROVAL: _____ DATE: _____

UBB SERIES - STAINLESS STEEL NARROW DEPTH, SOLID DOOR

Optimize space behind your bar.

SPECIAL FEATURES

- Galvanized top design is ideal for built-in, under-the-counter bars
- Eco-friendly R290 hydrocarbon refrigerant
- Sleek, stainless steel exterior with solid doors and a galvanized top
- Six epoxy-coated steel shelves accommodate up to 90 lb. each and are removable for flexibility
- Accommodates up to (3) ½ kegs
- Foamed-in-place polyurethane insulation
- 115V; 1/4 hp
- Type 201 stainless steel interior with LED lighting, coved corners, and food rated ETL Sanitation mark
- Digital controller features auto-defrost and maintains temperatures between 33-40°F



WARRANTY

RESIDENTIAL: Avantco assumes no liability for parts or labor coverage for component failure, factory defect or any other damages for units installed in non-commercial foodservice or residential applications.



Parts & Labor



Compressor

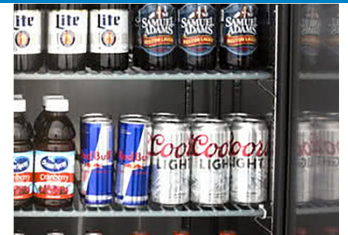

TECHNICAL DATA

Dimensions

Exterior Dimensions	72¾"W x 24⅞"D x 34¼"H
Interior Dimensions	60⅞"W x 18½"D x 29"H
Net Volume	21.6 cu. ft.
Product Capacity	(3) ½ kegs
Net Weight	331 lb.
Gross Weight	374 lb.
Packaging Dimensions	75¼"W x 27½"D x 41¾"H

Cooling

Temperature Range	33 - 40°F
Refrigerant	R290
Max. Ambient Temperature	90°F
Defrosting	Automatic
Temperature Controller	Digital
Horsepower	1/4

Construction

Exterior Material	Type 430 Stainless steel
Interior Material	Type 201 Stainless steel
Countertop Type	Galvanized steel
Door Type	Solid
Insulation Material	Foamed-in-place polyurethane
Shelf Size	(4) 19" x 18¼" + (2) 20½" x 18⅛"
Shelf Material	Epoxy-coated steel
Shelf Load Capacity	90 lb.

Electrical

Voltage	115
Amps	3.96
Hz	60
Phase	1
Plug Type	NEMA 5-15P
Electrical Cord Length	106"

PLAN VIEW

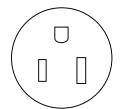
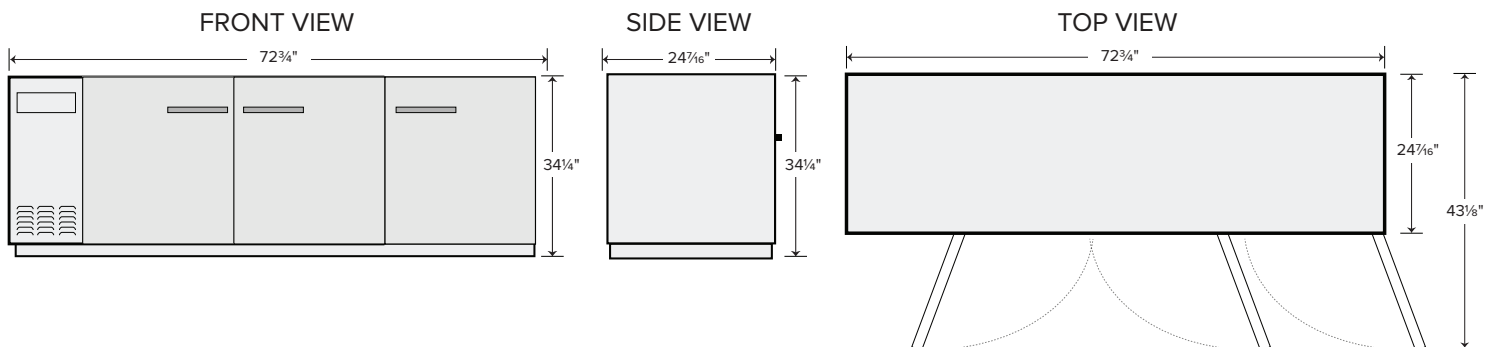

NEMA 5-15P