

SSPT Series Salad/Sandwich Prep Table

REFRIGERATION
AVANTCO

MODEL #178SSPT48HC

www.AvantcoRefrigeration.com

SSPT SERIES - SANDWICH & SALAD PREP

Ample prep space to create subs, salads, and sandwiches with convenient cold ingredient storage

CABINET CONSTRUCTION

Heavy duty construction includes 430 type stainless steel exterior with a 304 type stainless steel interior and an overall 35¼" working height.

Foamed-in-place CFC- and HCFC-free polyurethane insulation enhances the structural strength of the cabinet and helps increase energy efficiency. Insulated lid helps maintain safe product temperatures.

Full length, 11½" deep cutting board for easy prep work.

Easy-to-use recessed full-length stainless steel handles. Door stays open past 90° for easy loading, but will self-close under 90° to save energy.

REFRIGERATION SYSTEM

Environmentally safe R290 refrigerant. Rear-mounted condensing unit positioned for easy maintenance.

SHELVING

2 epoxy-coated wire shelves accommodate up to 90 lb. each.

MODEL FEATURES

Preprogrammed digital controller features auto-defrost function.

Top pan rail holds up to (12) 1/6 size, 6" deep food pans. Pan rail is air cooled from the bottom.

SPECIAL FEATURES

- Eco-friendly R290 hydrocarbon refrigerant
- Top holds up to (12) 1/6 size, 6" deep food pans
- Insulated lid helps maintain safe product temperature
- Full length, 3/4" thick, 11 1/2" deep cutting board for easy prep work
- Double self-closing swing doors with recessed full-length stainless steel handles
- 2 epoxy-coated wire shelves
- 430 type stainless steel exterior and 304 type stainless steel interior
- Digital temperature controls hold at 33-40°F
- 115V, 1/4 hp
- Pan rail is air cooled from the bottom



WARRANTY

RESIDENTIAL: Avantco assumes no liability for parts or labor coverage for component failure, factory defect or any other damages for units installed in non-commercial foodservice or residential applications.



Parts & Labor



Compressor



SSPT Series Salad/Sandwich Prep Table

MODELS #178SSPT48HC



www.AvantcoRefrigeration.com

TECHNICAL DATA

Dimensions

Exterior Dimensions	46 ³ / ₄ "W x 31"D x 42 ³ / ₈ "H
Interior Dimensions	42 ⁷ / ₈ "W x 23 ³ / ₄ "D x 23 ¹ / ₂ "H
Working Height	35 ¹ / ₄ "
Overall Height (Lid Open)	47 ¹ / ₄ "
Net Volume	12 cu. ft.
Net Weight	297 lb.
Gross Weight	348 lb.
Packaging Dimensions	51"W x 33 ³ / ₄ "D x 45 ¹ / ₂ "H

Construction

Exterior Material	Type 430 Stainless Steel
Interior Material	Type 304 Stainless Steel
Insulation Material	Foamed-in -place polyurethane
Shelf Size	(2) 20 ³ / ₄ " x 17 ¹ / ₁₆ "
Shelf Material	Epoxy-coated steel
Shelf Load Capacity	90 lb.

Cooling

Temperature Range	33°F - 40°F
Refrigerant	R290
Max. Ambient Temperature	90°F
Defrosting	Automatic
Temperature Controller	Digital
Horsepower	1/4

Electrical

Voltage	115
Amps	7.8
Hz	60
Phase	1
Plug Type	NEMA 5-15P
Electrical Cord Length	84"

PLAN VIEW

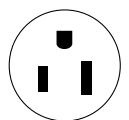
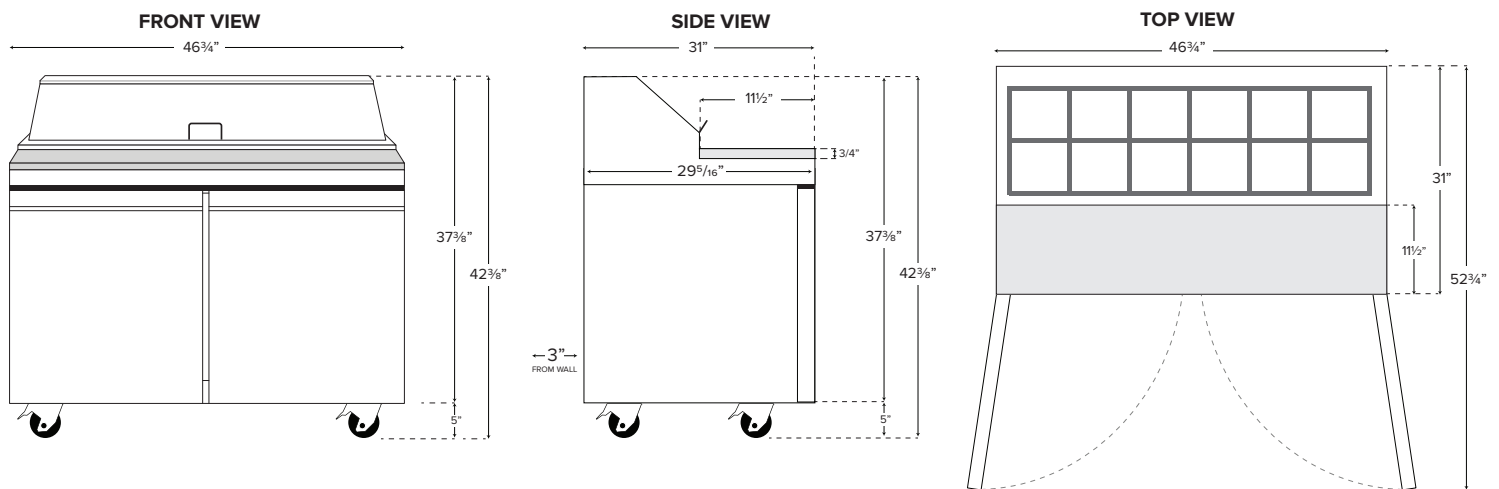

NEMA 5-15P