

PRODUCT: \_\_\_\_\_

QUANTITY: \_\_\_\_\_

ITEM #: \_\_\_\_\_

## Designed Smart

Developed for XTreme output!

- “XTREME SPEED” design combines new radiant heat system with our exclusive convection pre-heat system.
- Pre-heat convection system focuses hot air on bread in loading zone, pre-drying bread before toasting chamber.
- “XTREME SMART” air circulation system senses the perfect temperature in toaster cavity for the fastest startup.
- Xtreme-3 produces 1050 slices of toast per hour.
- Xtreme-3H produces 800 slices of toast per hour.

## XTreme Versatility!

- A variable speed control for the conveyor as well as controls for top and bottom heating elements produce optimum results in toasting color and texture.
- Able to handle all types of breads, bagels or muffins.

## XTreme Safety!

- New “Xtreme Smarts” (exclusive patent) protects employees from burns by keeping exteriors at “Xtreme Cool” temperatures.
- “Xtreme Smarts” are circulation system keeps cooling air circulating in toaster, even after the power switch is turned off protecting components and exteriors from excessive residual heat.
- Attractive front burn guard protects employees hands as they reach for toast in holding chamber.

## Energy Efficient!

- Power-saver stand-by switch for short off-periods helps reduce energy by 50% and allows quick reheating.

## Easy to Maintain and Service!

- Crumb tray under conveyor easily slides out for easy cleaning.
- Conveyor belt is easy to access for daily cleaning.
- Access to control systems from side panel for fast and easy service.

## Built Solid

### Built to Last

- Stainless steel construction for XTREME durability.
- XTREME heavy duty motor, drive chain, and controls are the most reliable in the industry.
- “XTREME SMART” air cooling system keeps critical components safe from heat.
- High limit switch prevents toaster from over heating.
- Metal sheathed heating elements.
- Provide enhanced durability and consumer safety vs. quartz tube heating elements that can shatter and contaminate food.

See reverse side for product specifications.



X\*TREME-3™ RADIANT CONVEYOR TOASTER

## APW Wyott Design Features

- Individually controlled top and bottom heating elements.
- Superfeeder included.
- Removable reflector tray for ease in cleaning.
- Self-dispensing bread drawer slides forward for removal of product.
- High temperature bearings never require lubrication.
- Standby switch conserves energy during slow periods.
- Lighted main power rocker switch.
- Stainless steel construction with aluminum front corners.
- Fully insulated and air-cooled (cool to the touch exteriors).
- 1” adjustable legs

## Options

- Stacking Kit

## Reliability backed by APW Wyott's Warranty

- All APW Wyott toasters are backed by a 1-year parts and labor warranty, including on-site service calls within 50 miles of authorized service technicians.
- Certified by the following agencies:



PRODUCT:

QUANTITY:

ITEM #:

Models:  XTRM-3  XTRM-3H

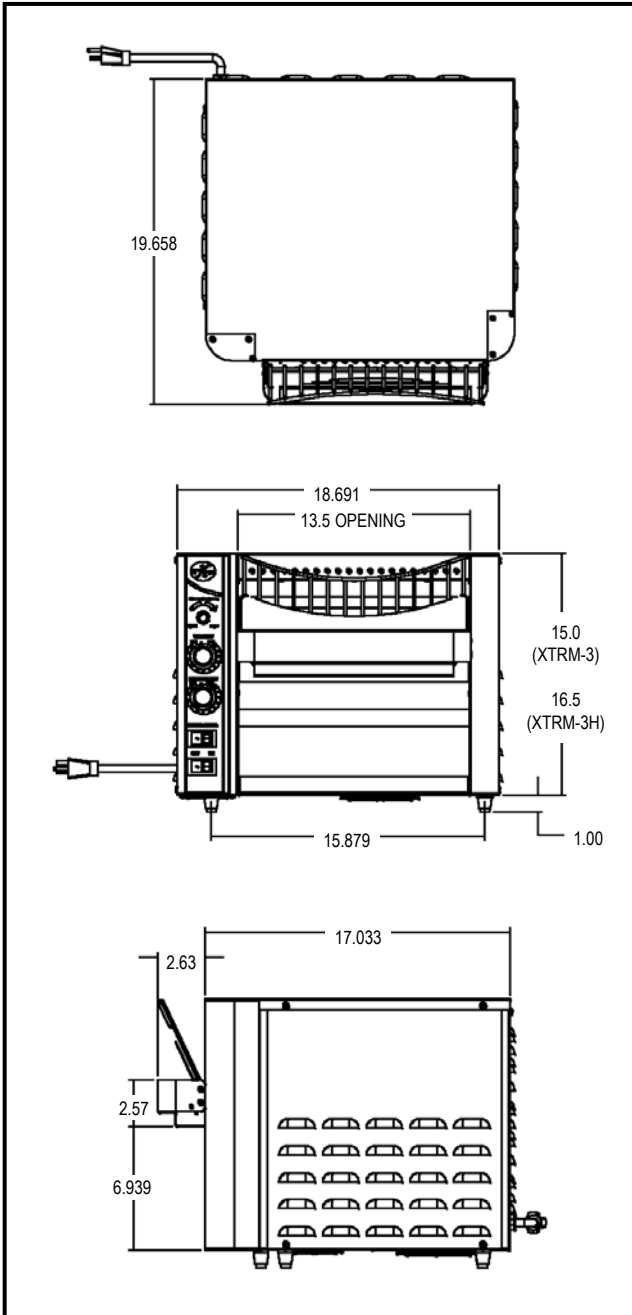

## PRODUCT SPECIFICATIONS

### Construction:

Powder coated aluminum front corners. Stainless steel housing and radiant reflector. Metal sheathed heating elements. Stainless steel wire conveyor belt. Stainless steel front wire guard. High temperature insulation protects control panel and exteriors.

### Electrical Information:

Each unit is equipped with a 39", three wire grounded power cord which terminates with a standard three pronged male plug. The 208/240V units use a NEMA 6-20P plug. 230V unit uses a NEMA plug

### Electrical Specifications:

|          |                      |
|----------|----------------------|
| XTRM-3:  | 208V, 3340W, 16 Amps |
|          | 240V, 3340W, 14 Amps |
|          | 230V, 3340W, 14 Amps |
| XTRM-3H: | 208V, 3340W, 16 Amps |
|          | 240V, 3340W, 14 Amps |
|          | 230V, 3340W, 14 Amps |

### Capacity:

1050 slices per hour

### Overall Dimensions:

Product opening is 1 1/2" on the XTRM-3 and 3" on the XTRM-3H

XTRM-3: 15"H x 18 5/16"W x 21 5/8"D

XTRM-3H: 16 1/2"H x 18 5/16"W x 21 5/8"D

### Shipping:

XTRM-3: 56 lbs. (25 kg)

XTRM-3H: 61 lbs. (27.68 kg)

Freight Class 100

FOB: Dallas, TX

## Consultant Specifications

Toasters are constructed of stainless steel and aluminum material. Range of belt speeds should be 28 to 75 seconds. Front corners and front conveyor guard should be painted. Toasters furnished with 1" adjustable legs. Infrared metal sheathed radiant heaters are located on the top and bottom and are individually controlled by Infinite Heat Controls. On/Off switch has Indicator Light that glows when the toaster is on. Power saver switch will be supplied that reduces energy by 50%. Product opening is 1 1/2", motors are permanently lubricated. Toaster will be Air Cooled with a thermostatically controlled fan that stays on until the toaster is cool to the touch. Control area has cooling fan. Units are UL listed, UL Sanitation, and Canadian UL approved.

\*APW Wyott reserves the right to modify specifications or discontinue models without incurring obligation.