



Lowerator® Trendline Adjustable II Plate Dispensers

Models: TL2 HTL2

PRODUCT:

QUANTITY:

ITEM #:

Designed Smart

Bid Specifications

Mobile, field adjustable Dish Dispenser features heavy-duty stainless steel frame construction and has a load capacity up to 210 lbs. per tube. Tube diameters are field adjustable by positioning stainless steel guide rods in proper head guide holes. The dispensing mechanism in APW Wyott's Lowerators® uses springs attached to a sliding support bar that rides both inside and outside the tube. This design feature prevents a stack of dishware from sticking in the down position, and releasing unexpectedly. Available in heated or unheated models. Tubular frame is welded construction. Unit has 4" polyurethane swivel casters, two with brakes.

Applications

Mobile Dish Dispenser utilizes Adjustube® II self-leveling tubes that are field adjustable for weight and diameter. Holds and dispenses plates, saucers, or bowls. Hole cutouts in base align lower end of tubes in position to prevent movement during transit. Field adjustable for varying weight loads up to 210 lbs. per tube.

- Promotes sanitary conditions.
- Provides finished appearance.
- Open-type design reduces overall weight load.
- Easy handling of dishware.
- Maximum stability and rigidity of unit.
- Dispensing head is stainless steel with five sets of reinforced guide holes for smooth, even operations.

Built Solid

Reliability backed by APW Wyott's Warranty

- All APW Wyott lowerators are backed by a 1-year parts and labor warranty, including on-site service calls within 50 miles of authorized service technicians.

- Certified by the following agencies:



Trendline Adjustable II Plate Dispensers

Options

Add options suffix number below to model number

- 5P 5" polyurethane casters, two with brakes
- RB Revolving corner bumpers

- TL2-9A TL2-12A TL2-9A/12A
- TL2-13
- HTL2-9A HTL2-12A HTL2-9A/12A
- HTL2-13

208/240 Versions are available

See reverse side for product specifications.



Lowerator® Trendline Adjustable II Plate Dispensers

Models: TL2 HTL2

PRODUCT: QUANTITY: ITEM #:

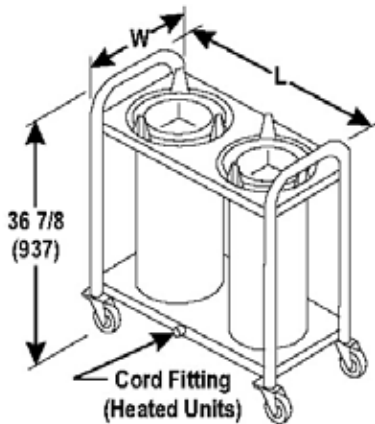

Models TL/HTL2

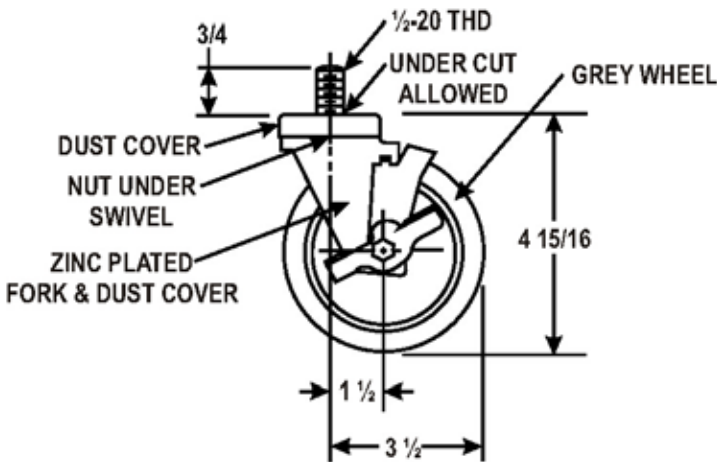
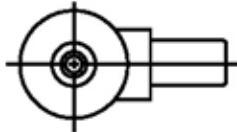

- 1. CASTER IS N.S.F APPROVED
- 2. LOAD CAP. 275 LBS

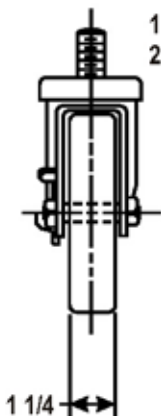

PRODUCT SPECIFICATIONS

Constructions:

Stainless steel frame and tubes, stainless steel guide rods, polyurethane swivel casters

Electrical Information:

Each heated tube has individual heaters and controls thermostat, on/off switch, light
Tube thermostats adjustable from 90 to 115F ,
Units provided with 5ft wire, 14 gauge power cord with NEMA 5-15P plug

Electrical Specification:

HTL2-9A	120V, 760W, 6.3Amps
HTL2-12A	120V, 1000W, 8.3Amps
HTL2-9A/12A	120V, 880W, 7.4Amps

Overall Dimensions:

35- 7/8" H X 17" W X 33-1/2"W
(26cm x 45cm x 56cm)

Capacity:

TL2-9 ^a , HTL2-9 ^a	3-1/2" to 9-1/8" (each tube) Max Load 131lbs
TL2-12 ^a , HTL2-12 ^a	9-1/4" to 11-7/8" (each tube) Max Load 175lbs
TL2-9A/12 ^a , HTL2-9A/12 ^a	3-1/2" to 9-1/8" (each tube) Max Load 131lbs 9-1/4" to 11-7/8" (each tube) Max Load 175lbs

Shipping:

TL2	65 lbs. (29.5kg)
HTL2	110 lbs. (49.9kg)
F.O.B Cheyenne, WY	

*APW Wyott reserves the right to modify specifications or discontinue models without incurring obligation.

