



Top Mount Hot Food Wells w/ Attached Controls

Models: HFWAT-2 HFWAT-3 HFWAT-4 HFWAT-5 HFWAT-6 ("D" after model # designates drain)
QUANTITY: ITEM #:

PRODUCT:

Designed Smart

- Heavy-duty Top mount insulated Rectangular Drop-In Food Wells (multiwells) designed for direct installation in metal or wood countertops by plugging directly into an existing outlet.
- Hot Food Wells are designed to accommodate standard size steamtable pans.
- Control box is mounted directly to bottom of unit.
- Well is constructed of deep-drawn 20 ga. Type 304 stainless steel, above countertop with 20 ga. aluminized outer housing with sides and bottom fully insulated.
- Units shipped with drain are provided with stainless steel 1/2" NPT drain welded to bottom of pan provided with removable screen.
- Unit is heated by a tubular heating element and designed in a "W-shape" for even heat distribution to pan base.
- Element is mounted under well and secured by aluminized deflector shield for maximum efficiency.

Built Solid

- 20 ga. Deep-drawn Type 304 stainless steel well pans.
- Stainless steel drain coupling.
- Compact housing—overall depth 8-11/16" and 11 1/2" in non-control area and 12 7/10" in the attached control area.
- Simplified construction reduces installation time and significantly reduces on-site electrical and plumbing costs.
- Unitized electrical wiring for single power hookup.

Reliability backed by APW Wyott's Warranty

- Backed by a 1 year parts & labor warranty.
- Certified by the following agencies:

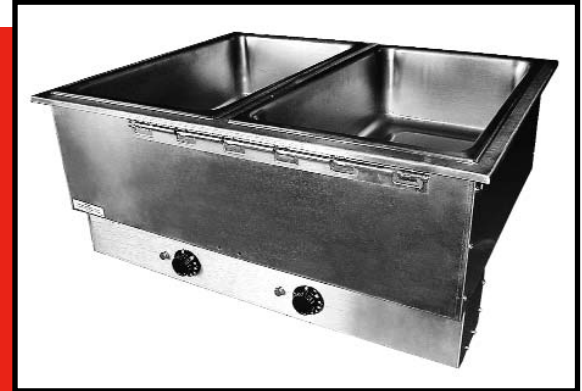

Top Mount Hot Food Well w/ Attached Controls

APW Wyott Design Features

- Unit standard with APW Wyott E-Z Locks on all four exterior sides for easy installation.
- The units feature complete UL construction including attached control box on bottom of bottom enclosure.
- Easy access to heating elements.
- Large indicating pilot light.
- Individual Thermostatic Controls
- Electric cord and plug for easy installation

Options

- Without Drain (No letter after model # designates no drain)
- With Drain ("D" after model # designates drain)
- Factory assembled 3/4 manifold drains (screens provided)
- Lever operated drain valve (56360)

See reverse side for product specifications.



APW Wyott Foodservice Equipment Company · 729 Third Ave., Dallas, TX 75226
(800) 527-2100 · (214) 421-7366 · Fax (214) 565-0976 · www.apwwyott.com · info@apwwyott.com

Rev. 5/22/2005



Top Mount Hot Food Wells w/ Attached Controls

Models: HFWAT-2 HFWAT-3 HFWAT-4 HFWAT-5 HFWAT-6 ("D" after model # designates drain)

PRODUCT:

QUANTITY:

ITEM #:

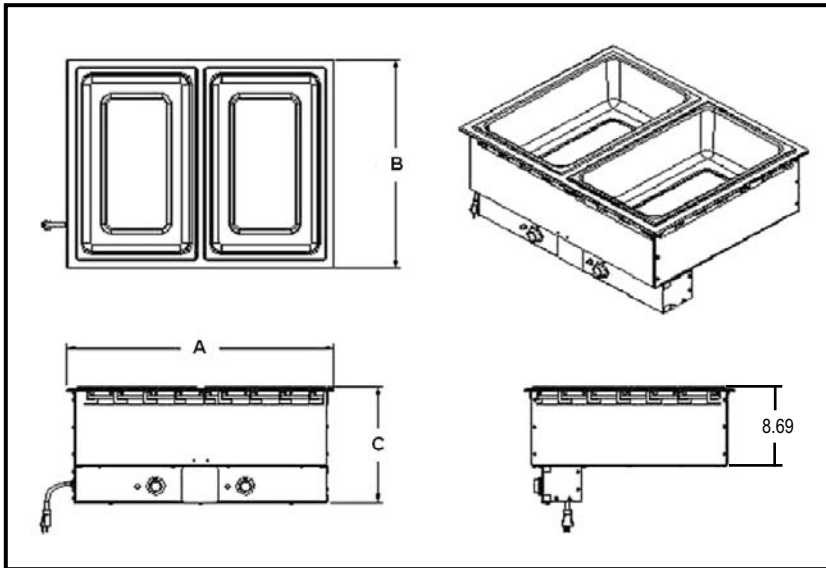

NOTE: Models with drain; coupling 1/2" NPT, stainless, 1 1/2" (3.8) long.

PRODUCT SPECIFICATIONS

Construction:

APW Wyott hot food wells are produced with stainless steel well pans, aluminum steel housing, and control boxes. Each unit is fully insulated with one inch thick insulation.

Shipping Information:

Freight Class: 92 1/2
FOB: Dallas, TX

Electrical Information:

Hot food wells are supplied with thermostatic control knobs to turn the system on and off. Each unit is supplied with at least a 72" cord and plug (see cords for ratings). All individual wells are heated with a 850 watt metal sheathed heating element.

Model	Electrical Ratings				Outside Dimensions			Cut-out		Ship Wt.
	volts	watts	amps	cord	A	B	C	D	E	
HFWAT-2	120	1700	14.2	5-20P	29.75" (75.6cm)	23.44" (59.5cm)	12.71" (32.79cm)	28.62" (72.7cm)	22.50" (57.2cm)	48 lbs (21.8kg)
HFWAT-3	208	2550	12.3	L6-20P	44.13" (112.1cm)	23.44" (59.5cm)	12.71" (32.79cm)	43.00" (109.2cm)	22.50" (57.2cm)	68 lbs (30.8kg)
HFWAT-4	208	3400	16.3	L6-30P	58.50" (148.6cm)	23.44" (59.5cm)	12.71" (32.79cm)	57.37" (145.7cm)	22.50" (57.2cm)	98 lbs (44.5kg)
HFWAT-5	208	4250	20.4	L6-30P	72.88" (185.1cm)	23.44" (59.5cm)	12.71" (32.79cm)	71.75" (182.2cm)	22.50" (57.2cm)	118 lbs (53.5kg)
HFWAT-6	208	5100	24.5	L6-50P	87.25" (221.6cm)	23.44" (59.5cm)	12.71" (32.79cm)	86.12" (218.7cm)	22.50" (57.2cm)	260 lbs (117.9kg)

*APW Wyott reserves the right to modify specifications or discontinue models without incurring obligation.



APW Wyott Foodservice Equipment Company · 729 Third Ave., Dallas, TX 75226
(800) 527-2100 · (214) 421-7366 · Fax (214) 565-0976 · www.apwwyott.com · info@apwwyott.com

Rev. 5/22/2005
1404