

PRODUCT:

QUANTITY:

ITEM:

Designed Smart

Increased Performance

- Workline high output gas burners generate 28,000 BTU's per burner
- Reduces amount of labor time to boil water by 50%
- Fast start-up to prime cooking temperatures
- Openings in the front allow the pilot light to be easily lit and adjusted without removing the front panel
- Thick, stainless steel construction on front panel and top skirt protects against kitchen "wear and tear" and rust
- Thick cast iron grates stand up to years of high output use
- Welded construction
- Curved bull-nose front extension protects employees from burns

Saves Time and Clean-up Labor Cost

- Maintenance is easier with bottom-mount grease collection pan and removable top grates
- Self-cleaning radiants
- Field convertible gas regulator

APW Wyott Design Features

- Heavy-duty stainless steel and aluminized steel construction
- 28,000 BTU/hr per cast iron burner
- Smooth action, infinitely adjustable gas valves turn 180 degrees, giving the operator ultimate control
- Field convertible gas regulator
- Removable cast-iron grate
- Stainless steel collection pans
- Adjustable viewable pilot
- 4" (10.2cm) heat-resistant, adjustable legs
- Front or top-serving

*Warranty does not include cooking grates or fireboxes.



Model GHPS-6i Standard Gas Hot Plate

Options & Accessories

- WOK Ring Accessory – Part # 21815507
- High altitude versions available (contact factory)

Reliability backed by APW Wyott's Warranty

All APW Wyott Heavy Duty Cookline Equipment is backed by a 2-year limited warranty and a 2-year on-site labor warrant. *

• Certified by the following agencies:



See reverse side for product specifications.

PRODUCT:

QUANTITY:

ITEM:

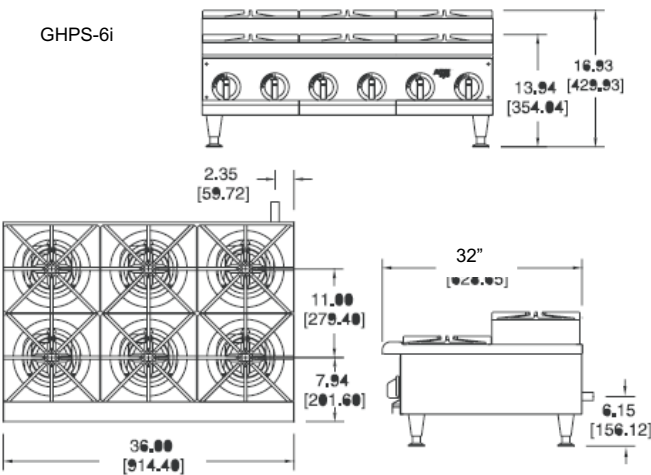
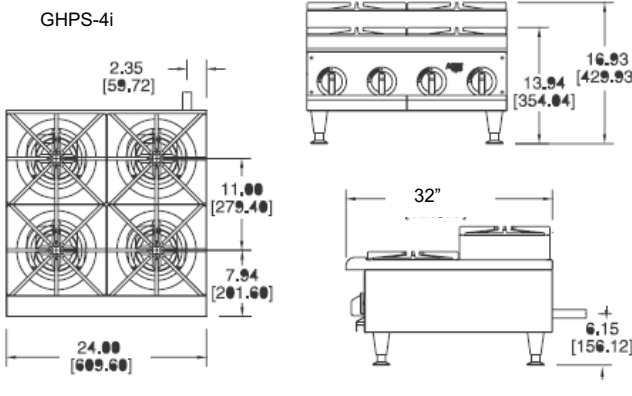
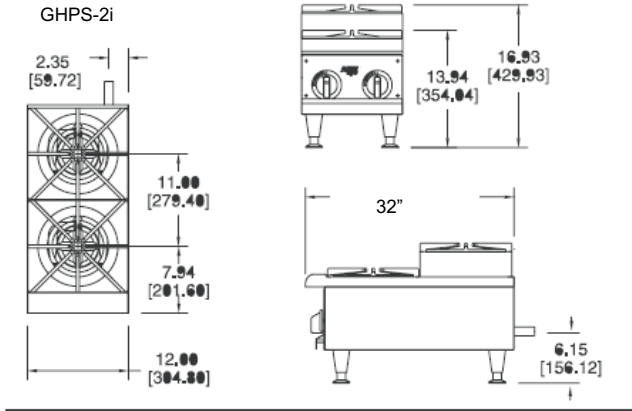

PRODUCT SPECIFICATIONS

CONSTRUCTION:

Stainless steel top skirt, crumb tray and front panel. Aluminized steel sides and back panel. Welded construction. Field convertible gas regulator. 4" adjustable legs.

Gas Specifications:

- GHPS-2i:** 2 burners, 28,000 BTU/Hr. each, total 56,000 BTU/Hr. input 2 manual infinitely adjustable controls (Propane is 56,000 BTU/Hr.)
- GHPS-4i:** 4 burners, 28,000 BTU/Hr. each, total 112,000 BTU/Hr. input 4 manual infinitely adjustable controls (Propane is 112,000 BTU/Hr.)
- GHPS-6i:** 6 burners, 28,000 BTU/Hr. each, total 168,000 BTU/Hr. input 6 manual infinitely adjustable controls (Propane is 168,000 BTU/Hr.)

Overall Dimensions:

- GHPS-2i:** 16 ¾"H x 12"W x 32"D
(42.5cm x 30.5cm x 63cm)
- GHPS-4i:** 16 ¾"H x 24"W x 32"D
(42.5cm x 61cm x 63cm)
- GHPS-6i:** 16 ¾"H x 36"W x 32"D
(42.5cm x 91.4cm x 63cm)

NOTE: Regulator and pipe add 1 ¼" to the rear of the unit.

Shipping:

- GHPS-2i:** 82 lbs (37 kg)
- GHPS-4i:** 146 lbs (66 kg)
- GHPS-6i:** 216 lbs (98 kg)

Freight Class: 70
FOB: Allen, TX 75013

*APW Wyott reserves the right to modify specifications or discontinue models without incurring obligation.